

SmartCell Gateway 200, Virtual SmartZone High-Scale and SmartZone 300 AAA (RADIUS) Interface Reference Guide

Supporting SmartZone 3.6

Copyright Notice and Proprietary Information

Copyright 2017 Brocade Communications Systems, Inc. All rights reserved.

No part of this documentation may be used, reproduced, transmitted, or translated, in any form or by any means, electronic, mechanical, manual, optical, or otherwise, without prior written permission of or as expressly provided by under license from Brocade.

Destination Control Statement

Technical data contained in this publication may be subject to the export control laws of the United States of America. Disclosure to nationals of other countries contrary to United States law is prohibited. It is the reader's responsibility to determine the applicable regulations and to comply with them.

Disclaimer

THIS DOCUMENTATION AND ALL INFORMATION CONTAINED HEREIN ("MATERIAL") IS PROVIDED FOR GENERAL INFORMATION PURPOSES ONLY. BROCADE and RUCKUS WIRELESS, INC. AND THEIR LICENSORS MAKE NO WARRANTY OF ANY KIND, EXPRESS OR IMPLIED, WITH REGARD TO THE MATERIAL, INCLUDING, BUT NOT LIMITED TO, THE IMPLIED WARRANTIES OF MERCHANTABILITY, NON-INFRINGEMENT AND FITNESS FOR A PARTICULAR PURPOSE, OR THAT THE MATERIAL IS ERROR-FREE, ACCURATE OR RELIABLE. BROCADE and RUCKUS RESERVE THE RIGHT TO MAKE CHANGES OR UPDATES TO THE MATERIAL AT ANY TIME.

Limitation of Liability

IN NO EVENT SHALL BROCADE or RUCKUS BE LIABLE FOR ANY DIRECT, INDIRECT, INCIDENTAL, SPECIAL OR CONSEQUENTIAL DAMAGES, OR DAMAGES FOR LOSS OF PROFITS, REVENUE, DATA OR USE, INCURRED BY YOU OR ANY THIRD PARTY, WHETHER IN AN ACTION IN CONTRACT OR TORT, ARISING FROM YOUR ACCESS TO, OR USE OF, THE MATERIAL.

Trademarks

Ruckus Wireless, Ruckus, the bark logo, BeamFlex, ChannelFly, Dynamic PSK, FlexMaster, Simply Better Wireless, SmartCell, SmartMesh, SmartZone, Unleashed, ZoneDirector and ZoneFlex are trademarks of Ruckus Wireless, Inc. in the United States and in other countries. Brocade, the B-wing symbol, MyBrocade, and ICX are trademarks of Brocade Communications Systems, Inc. in the United States and in other countries. Other trademarks may belong to third parties.

Contents

Preface	5
Document Conventions.....	5
Notes, Cautions, and Warnings.....	5
Command syntax conventions.....	5
Document feedback.....	6
Ruckus resources.....	6
Online Training Resources.....	6
Contacting Ruckus Customer Services and Support.....	7
What Support Do I Need?.....	7
Open a Case.....	7
Self-Service Resources.....	7
About This Guide	9
About this Guide.....	9
Terminology.....	9
References.....	10
EAP Full Authentication	11
EAP Full Authentication.....	11
RADIUS Access Request [ID].....	12
RADIUS Access Challenge [EAP Request (SIM Start)].....	16
RADIUS Access Request [EAP Response (NONCE_MT)].....	18
RADIUS Access Challenge [EAP Request (RAND, MAC)].....	22
RADIUS Access Request [EAP Response (SRES)].....	24
RADIUS Access Accept [EAP Success (MSK)].....	26
EAP Full Authentication Overview.....	30
EAP - Full Authentication – 3GPP Solution.....	31
RADIUS Access Request [ID].....	32
RADIUS Access Challenge [EAP Request (SIM Start)]	35
RADIUS Access Request [EAP Response (NONCE_MT)].....	36
RADIUS Access Challenge [EAP Request (RAND, MAC)].....	41
RADIUS Access Request [EAP Response (SRES)].....	43
RADIUS Access Accept [EAP Success (MSK)].....	46
Authorization Access Request.....	51
Authorization Access Accept.....	52
RADIUS Access Reject.....	53
Hotspot (WISPr) Authentication and Accounting	55
Hotspot (WISPr) Authentication and Accounting Overview.....	55
Hotspot (WISPr) Authentication Request	56
Hotspot (WISPr) Authentication Response.....	61
Hotspot (WISPr) Accounting Request [Start].....	63
Hotspot (WISPr) Accounting Request [Stop/Interim].....	67
Hotspot (WISPr) Accounting Response.....	72
Hotspot 2.0 Authentication	73
Hotspot 2.0 Authentication Overview.....	73
SIM Based Authentication - Access Request.....	73

R2 Device Authentication.....	74
Access Request.....	75
Access Response.....	76
Hotspot 2.0 VSAs.....	77
Accounting - Controller Initiated Accounting Messages.....	79
Accounting - Controller Initiated Accounting Messages (TTG Sessions).....	79
RADIUS Accounting Request [Start].....	80
RADIUS Accounting Request [Stop/Interim Update].....	89
RADIUS Accounting Response.....	94
AP Initiated Accounting Messages (PDG/LBO Sessions).....	95
Accounting Start Messages.....	96
Accounting Interim Update and Stop Messages.....	100
Accounting On Messages.....	105
Accounting Off Messages.....	106
AAA Server Dynamic Authorization and List of Vendor Specific Attributes.....	109
Dynamic Authorization and List of Vendor Specific Attributes - AAA Server.....	109
Service Authorization	109
Change of Authorization (CoA) Messages - Not Set to Authorize Only.....	110
Change of Authorization Acknowledge Message (CoA Ack).....	112
Change of Authorization Negative Acknowledge Messages (CoA NAK)	112
Disconnect Messages.....	113
Acknowledgment of Disconnect Messages (DM Ack).....	115
Negative Acknowledge of Disconnect Messages (DM NAK).....	115
Disconnect Messages - Dynamic Authorization Client (AAA server).....	115
WISPr Vendor Specific Attributes.....	116
Ruckus Wireless Vendor Specific Attributes.....	116
AP Roaming Scenarios.....	121
AP Roaming Scenarios Overview.....	121
Roaming from AP1 to AP2 - PMK / OKC Disabled.....	122
Roaming from AP1 to AP2 - PMK / OKC Enabled.....	122
AP1 to AP2 Connected to Different Controller Node - PMK / OKC Disabled.....	123
Use Cases.....	125
Use Case Scenarios.....	125
DPSK for Cloud over RADIUS.....	129
DPSK For Cloud Over Radius Overview.....	129

Preface

- Document Conventions..... 5
- Command syntax conventions..... 5
- Document feedback..... 6
- Ruckus resources..... 6
- Online Training Resources..... 6
- Contacting Ruckus Customer Services and Support..... 7

Document Conventions

The following tables list the text and notice conventions that are used throughout this guide.

TABLE 1 Text conventions

Convention	Description	Example
monospace	Identifies command syntax examples.	<code>device(config)# interface ethernet 1/1/6</code>
bold	User interface (UI) components such as screen or page names, keyboard keys, software buttons, and field names	On the Start menu, click All Programs .
<i>italics</i>	Publication titles	Refer to the <i>Ruckus Small Cell Release Notes</i> for more information

Notes, Cautions, and Warnings

Notes, cautions, and warning statements may be used in this document. They are listed in the order of increasing severity of potential hazards.

NOTE

A NOTE provides a tip, guidance, or advice, emphasizes important information, or provides a reference to related information.



CAUTION

A CAUTION statement alerts you to situations that can be potentially hazardous to you or cause damage to hardware, firmware, software, or data.



DANGER

A DANGER statement indicates conditions or situations that can be potentially lethal or extremely hazardous to you. Safety labels are also attached directly to products to warn of these conditions or situations.

Command syntax conventions

Bold and italic text identify command syntax components. Delimiters and operators define groupings of parameters and their logical relationships.

Convention

bold text

Description

Identifies command names, keywords, and command options.

Preface

Document feedback

Convention

italic text

[]

{ x | y | z }

x | y

< >

...

\

Description

Identifies a variable.

Syntax components displayed within square brackets are optional.

Default responses to system prompts are enclosed in square brackets.

A choice of required parameters is enclosed in curly brackets separated by vertical bars. You must select one of the options.

A vertical bar separates mutually exclusive elements.

Nonprinting characters, for example, passwords, are enclosed in angle brackets.

Repeat the previous element, for example, *member{member...}*.

Indicates a “soft” line break in command examples. If a backslash separates two lines of a command input, enter the entire command at the prompt without the backslash.

Document feedback

Ruckus is interested in improving its documentation and welcomes your comments and suggestions.

You can email your comments to Ruckus at: docs@ruckuswireless.com

When contacting us, please include the following information:

- Document title and release number
- Document part number (on the cover page)
- Page number (if appropriate)
- For example:
 - SmartCell Gateway 200 S2a Interface Reference Guide for SmartZone 3.5.1
 - Part number: 800-71306-001
 - Page 88

Ruckus resources

Visit the Ruckus website to locate related documentation for your product and additional Ruckus resources.

Release Notes and other user documentation are available at <https://support.ruckuswireless.com/documents>. You can locate documentation by product or perform a text search.

White papers, data sheets, and other product documentation are available at www.ruckuswireless.com.

Online Training Resources

To access a variety of online Ruckus training modules, including free introductory courses to wireless networking essentials, site surveys, and Ruckus products, visit the Ruckus Training Portal at <https://training.ruckuswireless.com>.

Contacting Ruckus Customer Services and Support

The Customer Services and Support (CSS) organization is available to provide assistance to customers with active warranties on their Ruckus Networks products, and customers and partners with active support contracts.

For product support information and details on contacting the Support Team, go directly to the Support Portal using <https://support.ruckuswireless.com>, or go to <https://www.ruckuswireless.com> and select **Support**.

What Support Do I Need?

Technical issues are usually described in terms of priority (or severity). To determine if you need to call and open a case or access the self-service resources use the following criteria:

- Priority 1 (P1)—Critical. Network or service is down and business is impacted. No known workaround. Go to the **Open a Case** section.
- Priority 2 (P2)—High. Network or service is impacted, but not down. Business impact may be high. Workaround may be available. Go to the **Open a Case** section.
- Priority 3 (P3)—Medium. Network or service is moderately impacted, but most business remains functional. Go to the **Self-Service Resources** section.
- Priority 4 (P4)—Low. Request for information, product documentation, or product enhancements. Go to the **Self-Service Resources** section.

Open a Case

When your entire network is down (P1), or severely impacted (P2), call the appropriate telephone number listed below to get help:

- Continental United States: 1-855-782-5871
- Canada: 1-855-782-5871
- Europe, Middle East, Africa, and Asia Pacific, toll-free numbers are available at <https://support.ruckuswireless.com/contact-us> and Live Chat is also available.

Self-Service Resources

The Support Portal at <https://support.ruckuswireless.com/contact-us> offers a number of tools to help you to research and resolve problems with your Ruckus products, including:

- [Technical Documentation](https://support.ruckuswireless.com/documents)—<https://support.ruckuswireless.com/documents>
- [Community Forums](https://forums.ruckuswireless.com/ruckuswireless/categories)—<https://forums.ruckuswireless.com/ruckuswireless/categories>
- [Knowledge Base Articles](https://support.ruckuswireless.com/answers)—<https://support.ruckuswireless.com/answers>
- [Software Downloads and Release Notes](https://support.ruckuswireless.com/software)—<https://support.ruckuswireless.com/software>
- [Security Bulletins](https://support.ruckuswireless.com/security)—<https://support.ruckuswireless.com/security>

Using these resources will help you to resolve some issues, and will provide TAC with additional data from your troubleshooting analysis if you still require assistance through a support case or RMA. If you still require help, open and manage your case at https://support.ruckuswireless.com/case_management

About This Guide

- About this Guide..... 9
- Terminology.....9
- References..... 10

About this Guide

This SmartCell Gateway™ SCG200 and Virtualized SmartZone (vSZ-H) High-Scale AAA (RADIUS) Interface Reference Guide describes the interface between the SCG200/vSZ-H (collectively referred to as “the controller” throughout this guide) and the Authentication, Authorization and Accounting (AAA) server. It describes the message flow between the controller and AAA for EAP-based full authentication, authorization, and accounting.

This guide is written for service operators and system administrators who are responsible for managing, configuring, and troubleshooting Ruckus Wireless devices. Consequently, it assumes a basic working knowledge of local area networks, wireless networking, and wireless devices.

NOTE

If release notes are shipped with your product and the information there differs from the information in this guide, follow the instructions in the release notes.

Most user guides and release notes are available in Adobe Acrobat Reader Portable Document Format (PDF) or HTML on the Ruckus Wireless Support Web site at <https://support.ruckuswireless.com/contact-us>.

Terminology

The table lists the terms used in this guide.

TABLE 2 Terms used in this guide

Terminology	Description
AAA	Authentication, Authorization, and Accounting
CHAP	Challenge Handshake Authentication Protocol
EAP	Extensible Authentication Protocol
EPS	Evolved Packet System
GGSN	Gateway GPRS Support Node
GSN	GPRS Support Node
HLR	Home Location Register
LCS	Location Services
MAP	Mobile Application Part
MTU	Maximum Transmission Unit
MWSG	Metro Wireless Security Gateway
OSU	Online Sign-Up
Passpoint	Hotspot 2.0 certification
PKI	Public Key Infrastructure

TABLE 2 Terms used in this guide (continued)

Terminology	Description
PDP	Packet Data Protocol
PPS-MO	Per Provider Subscription Management Object
R-WSG/WSG	Ruckus Wireless Security Gateway
Release1 Device	Hotspot 2.0 Release1 specification compliant device
Release 2 Device	Hotspot 2.0 Release 2 passpoint enabled device
RAC	Radio Access Controller
RADIUS	Remote Access Dial In User Service
TEID	Tunnel End Point Identifier
UE	User Equipment
WFA	Wi-Fi Alliance

References

The table lists the references used in this guide

TABLE 3 References used in this guide

Serial Number	Reference	Description
1.	3GPP TS 23.234	3GPP system to WLAN inter-working
2.	3GPP TS 33.234 	Wireless Local Area Network (WLAN) inter-working security
3.	RFC 2865	Remote authentication dial in user service (RADIUS)
4.	RFC 2866	RADIUS accounting
5.	RFC 5176	Dynamic authorization extensions to remote authentication dial in user service (RADIUS)
6.	RFC 5580	Carrying Location Objects in RADIUS and Diameter (August 2009)

EAP Full Authentication

- EAP Full Authentication..... 11
- EAP Full Authentication Overview..... 30
- EAP - Full Authentication – 3GPP Solution.....31
- RADIUS Access Reject.....53

EAP Full Authentication

This is authentication and authorization combined together.

In this call flow, the controller acts as an AAA proxy server. It does not initiate a separate access request message to perform service authorization. Parameters needed by the controller (TTG) to establish the GTP tunnel (QoS, Charging Characteristics, MSISDN) are expected in the access accept message from AAA. The figure below shows the detailed call flow.

FIGURE 1 Combined authentication sequence diagram

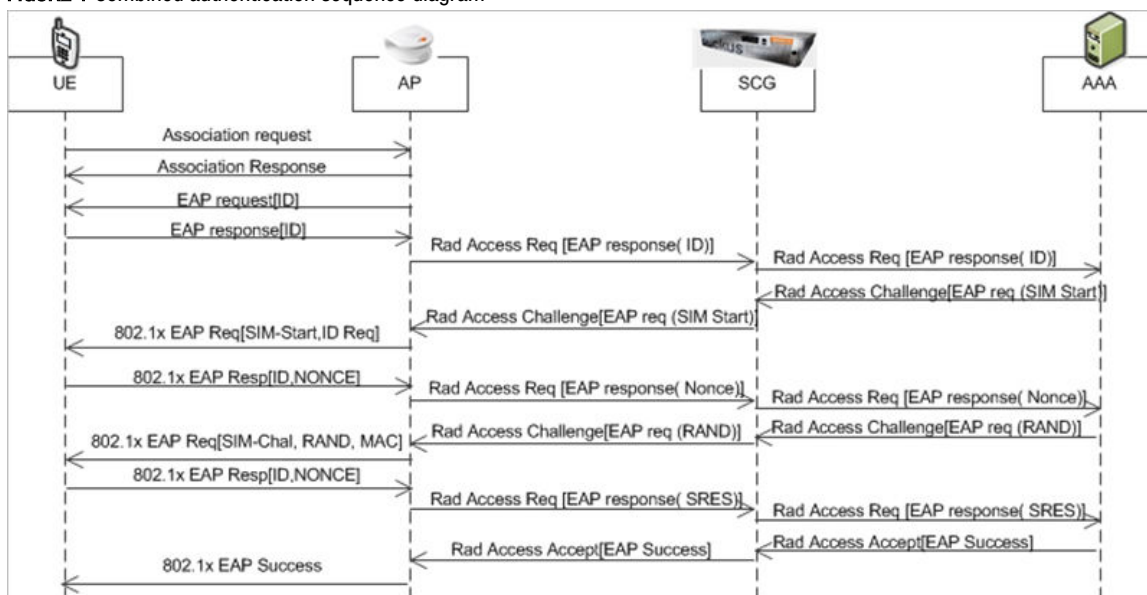

This section covers:

- [RADIUS Access Request \[ID\]](#) on page 12
- [RADIUS Access Challenge \[EAP Request \(SIM Start\)\]](#) on page 16
- [RADIUS Access Request \[EAP Response \(NONCE_MT\)\]](#) on page 18
- [RADIUS Access Challenge \[EAP Request \(RAND, MAC\)\]](#) on page 22
- [RADIUS Access Request \[EAP Response \(SRES\)\]](#) on page 24
- [RADIUS Access Accept \[EAP Success \(MSK\)\]](#) on page 26

RADIUS Access Request [ID]

The table lists the attribute details for the first message sent by the controller to the AAA server.

NOTE

When RFC 5580 is enabled for a WLAN and the AAA server supports RFC 5580, location-related information is not conveyed in access requests. Instead, the exchange of location-related information is negotiated between the controller and the AAA server as stipulated in RFC 5580.

TABLE 4 RADIUS access request attributes

Attribute	Attribute ID	Presence	Type	Description
User-Name	1	M	String	Indicates the name of the user to be authenticated.
User-Password	2	C	String	This attribute indicates the password of the user to be authenticated. It is mandatory for PAP authentication.
CHAP-Password	3	C	String	This attribute indicates the value provided by a CHAP user in response to the access-challenge. It is mandatory for CHAP authentication.
NAS-IP-Address	4	C	Integer	This attribute is the IP address of the AP which is serving the station or controller's control IP address, controller's management IP address and user defined value.
NAS-Port	5	O	Integer	This attribute indicates the physical port number of the NAS which authenticates the user. The controller uses the association ID for the STA in the AP to represent this.
Service-Type	6	O	Integer	Indicates the type of service based on the user request or the type of service to be provided.
Framed MTU	12	O	Integer	Indicates the Maximum Transmission Unit (MTU) to be configured for the user, when it is not negotiated by some other means.
Vendor-Specific	26	C	Integer	Vendor ID: Ruckus:25053 VSA: Ruckus-SCG-CBLADE-IP (7) VSA Length: 6 Reports the control plane IP address. Ruckus VSAs are received from Ruckus APs only. It is optional for 3rd party APs.

TABLE 4 RADIUS access request attributes (continued)

Attribute	Attribute ID	Presence	Type	Description
Vendor-Specific	26	C	Integer	Vendor ID:Ruckus:25053 VSA: Ruckus-SCG-DBLADE-IP (8) VSA Length: 6 Reports the control plane IP address. Ruckus VSAs are received from Ruckus APs only. It is optional for 3rd party APs.
Vendor-Specific	26	C	String	Vendor ID: Ruckus:25053 VSA: Ruckus-SSID (3) VSA Length: Variable Reports the associated WLANs SSID in access request and accounting packet. Ruckus VSAs are received from Ruckus APs only. It is optional for 3rd party APs.
Vendor-Specific	26	C	String	Vendor ID: Ruckus:25053 VSA: Ruckus-Location (5) VSA Length: Variable Reports the device location for this AP. This is a configurable value in the device location setting. Ruckus VSA is received only from Ruckus AP. It is optional for 3rd party APs.
Called Station ID	30	O	String	This attribute allows NAS to send the ID (BSSID), which is called by the user. It is MAC of the AP. It supports 2 types of values, namely BSSID:SSID, where BSSID is the MAC address of the WLAN on AP. The second value is AP-MAC:SSID, where AP-MAC is the MAC address of the AP. The letters in the MAC address are in uppercase. For example: 11-22-33-AA-BB-CC:SSID.
Calling Station ID	31	M	String	Allows NAS to send the ID (UE MAC), which indicates as to who is calling this server.
NAS-Identifier	32	C	Integer	NAS-IP-Address or NAS-Identifier attribute is mandatory in received messages. It supports 3 types of values, namely BSSID (MAC address of the

TABLE 4 RADIUS access request attributes (continued)

Attribute	Attribute ID	Presence	Type	Description
				WLAN on AP), AP-MAC (MAC address of AP) and user defined address (maximum length of 62).
Proxy-State	33	O	Octets	This attribute is available to be sent by a proxy server (controller) to another server (AAA server) when forwarding an access request, accounting request (start, stop or interim) and must be returned unmodified in the access accept, access reject, access challenge and accounting response.
Acct-Session-ID	44	M	Integer	This attribute is a unique accounting identity to facilitate easy matching of start, interim and stop records in a log file. The start, interim and stop records for a given session must have the same Acct-Session-ID.
NAS-Port-Type	61	M	Integer	Indicates the physical port type of NAS, which authenticates the user.
Connect-Info	77	O	String	This attribute is sent from the NAS to indicate the nature of the user's connection.
EAP Message	79	M	Octets	This attribute encapsulates Extensible Authentication Protocol (EAP) packets, which allows NAS to authenticate dial-in users via EAP, without having to understand the EAP protocol (EAP payload, EAP-SIM or EAP-AKA).
Message Authenticator	80	M	Octets	This attribute is used in signing access requests for preventing spoofing of access requests using CHAP, ARAP or EAP authentication methods. It authenticates this whole RADIUS packet - HMAC-MD5 (Type Identifier Length Request Authenticator Attributes).
Chargeable User ID	89	M	String	This attribute sends a null value during authentication.
Operator-Name	126	M	String	The attribute identifies the owner of the access network

TABLE 4 RADIUS access request attributes (continued)

Attribute	Attribute ID	Presence	Type	Description
				<p>by the AAA server. It is encoded as per RFC 5580.</p> <p>NOTE This attribute is included only if the location delivery method is Out of Band as specified in RFC 5580</p>
Location-Information	127	M	Octets	<p>This is a composite attribute, which provides meta data about the location information. It is encoded as per RFC 5580.</p> <p>NOTE This attribute is included only if the location delivery method is Out of Band as specified in RFC 5580.</p>
Location-Data	128	M	Octets	<p>This attribute contains the actual location information. It is encoded as per RFC 5580.</p> <p>NOTE This attribute is included only if the location delivery method is Out of Band as specified in RFC 5580.</p>
Basic-Location-Policy-Rules	129	M	Octets	<p>This attribute provides the basic privacy policy associated to the location information. It is encoded as per RFC 5580.</p> <p>NOTE This attribute is included only if the location delivery method is Out of Band as specified in RFC 5580.</p>
Extended-Location-Policy-Rules	130	M	Octets	<p>This attribute provides the extended privacy policy for the target whose location is specified. This attribute is</p>

TABLE 4 RADIUS access request attributes (continued)

Attribute	Attribute ID	Presence	Type	Description
				sent with the above attribute (basic location policy). It is encoded as per RFC 5580. NOTE This attribute is included only if the location delivery method is Out of Band as specified in RFC 5580.
Location-Capable	131	M	Integer	This attribute is sent in RADIUS access request during the authentication phase to indicate the AP's capability for providing the location. Encoded as per RFC 5580. NOTE This attribute is included only if location delivery method is not Out of Band.

RADIUS Access Challenge [EAP Request (SIM Start)]

The table lists the attribute details of the first message sent by the AAA to the controller, which is forwarded to the RADIUS client (access point).

TABLE 5 RADIUS access challenge attributes

Attribute	Attribute ID	Presence	Type	Description
State	24	O	Integer	This attribute is sent by the server to the client in an access-challenge message and must be sent unmodified from the client to the server in the new access request message - a reply to that challenge, if any.
Proxy-State	33	C	Integer	This attribute is available to be sent by a proxy server (controller) to another server (AAA server) when forwarding an access request, accounting request (start, stop or interim) and must be returned unmodified in the access accept, access reject, access-challenge and accounting response.
EAP Message	79	M	Integer	This attribute encapsulates Extensible Authentication Protocol (EAP) packets, which allows NAS to authenticate dial-in users via EAP, without having to

TABLE 5 RADIUS access challenge attributes (continued)

Attribute	Attribute ID	Presence	Type	Description
				understand the EAP protocol (EAP payload, EAP-SIM or EAP-AKA).
Message Authenticator	80	M	Integer	This attribute is used in signing access requests for preventing spoofing of access requests using CHAP, ARAP or EAP authentication methods. It authenticates this whole RADIUS packet - HMAC-MD5 (Type Identifier Length Request Authenticator Attributes).
Chargeable User ID	89	O	Integer	This attribute sends a null value during authentication.
Basic-Location-Policy-Rules	129	M	String	This attribute provides the basic privacy policy associated to the location information. It is encoded as per RFC 5580. NOTE This attribute is expected from the AAA server in the initial request location delivery method mentioned in RFC 5580.
Extended-Location-Policy-Rules	130	M	String	This attribute provides the extended privacy policy for the target whose location is specified. This attribute is sent with the above attribute (basic location policy). It is encoded as per RFC 5580. NOTE This attribute is expected from the AAA server in the initial request location delivery method mentioned in RFC 5580.
Requested-Location-Info	132	M	Integer	This attribute is only used in messages sent by the AAA server towards the AP. Using this attribute the AAA server indicates its request for location information. Encoded as per RFC 5580. NOTE This attribute is expected from the AAA server in the initial request location delivery method mentioned in RFC 5580.

RADIUS Access Request [EAP Response (NONCE_MT)]

The table lists the attribute details of messages sent by the controller to the AAA server and responses received from the UEs.

TABLE 6 RADIUS access request attributes

Attribute	Attribute ID	Presence	Type	Description
User-Name	1	M	String	Indicates the name of the user to be authenticated.
User-Password	2	C	String	This attribute indicates the password of the user to be authenticated. It is mandatory for PAP authentication.
CHAP-Password	3	C	String	This attribute indicates the value provided by a CHAP user in response to the access-challenge. It is mandatory for CHAP authentication.
NAS-IP-Address	4	C	Integer	This attribute is the IP address of the AP which is serving the station or controller's control IP address, controller's management IP address and user defined value.
NAS-Port	5	O	Integer	This attribute indicates the physical port number of the NAS which authenticates the user. The controller uses the association ID for the STA in the AP to represent this.
Service-Type	6	O	Integer	Indicates the type of service based on the user request or the type of service to be provided.
Framed MTU	12	O	Integer	Indicates the Maximum Transmission Unit (MTU) to be configured for the user, when it is not negotiated by some other means.
State	24	O	Integer	This attribute is sent by the server to the client in an access-challenge message and must be sent unmodified from the client to the server in the new access request message - a reply to that challenge, if any.
Vendor-Specific	26	C	Integer	VSA Length: 6 Reports the associated WLANs ID. Ruckus VSA is received only from Ruckus AP. It is optional for 3rd party APs.
Vendor-Specific	26	C	Integer	Vendor ID: Ruckus:25053

TABLE 6 RADIUS access request attributes (continued)

Attribute	Attribute ID	Presence	Type	Description
				VSA: Ruckus-SCG-CBLADE-IP (7) VSA Length: 6 Reports the control plane IP address. Ruckus VSAs are received from Ruckus APs only. It is optional for 3rd party APs.
Vendor-Specific	26	C	Integer	Vendor ID: Ruckus:25053 VSA: Ruckus-SCG-DBLADE-IP (8) VSA Length: 6 Reports the data plane IP address. Ruckus VSAs are received from Ruckus APs only. It is optional for 3rd party APs.
Vendor-Specific	26	C	String	Vendor ID: Ruckus:25053 VSA: Ruckus-SSID (3) VSA Length: Variable Reports the associated WLANs SSID in access request and accounting packet. Ruckus VSAs are received from Ruckus APs only. It is optional for 3rd party APs.
Vendor-Specific	26	C	String	Vendor ID: Ruckus:25053 VSA: Ruckus-Location (5) VSA Length: Variable Reports the device location for this AP. This is a configurable value in the device location setting. Ruckus VSA is received only from Ruckus AP. It is optional for 3rd party APs.
Called Station ID	30	O	Integer	This attribute allows NAS to send the ID (BSSID), which is called by the user. It is MAC of the AP. It supports 2 types of values, namely BSSID:SSID, where BSSID is the MAC address of the WLAN on AP. The second value is AP-MAC:SSID, where AP-MAC is the MAC address of the AP. The letters in the MAC address are in uppercase. For example: 11-22-33-AA-BB-CC:SSID.

TABLE 6 RADIUS access request attributes (continued)

Attribute	Attribute ID	Presence	Type	Description
Calling Station ID	31	M	Integer	Allows NAS to send the ID (UE MAC), which indicates as to who is calling this server.
NAS-Identifier	32	C	Integer	NAS-IP-Address or NAS-Identifier attribute is mandatory in received messages. It supports 3 types of values, namely BSSID (MAC address of the WLAN on AP), AP-MAC (MAC address of AP) and user defined address (maximum length of 62).
Proxy-State	33	O	Integer	This attribute is available to be sent by a proxy server (controller) to another server (AAA server) when forwarding an access request, accounting request (start, stop or interim) and must be returned unmodified in the access accept, access reject, access challenge and accounting response.
Acct-Session-ID	44	M	Integer	This attribute is a unique accounting identity to facilitate easy matching of start, interim and stop records in a log file. The start, interim and stop records for a given session must have the same Acct-Session-ID.
NAS-Port-Type	61	M	Integer	Indicates the physical port type of NAS, which authenticates the user.
Connect-Info	77	O	Integer	This attribute is sent from the NAS to indicate the nature of the user's connection.
EAP Message	79	M	Integer	This attribute encapsulates Extensible Authentication Protocol (EAP) packets, which allows NAS to authenticate dial-in users via EAP, without having to understand the EAP protocol (EAP payload, EAP-SIM or EAP-AKA).
Message Authenticator	80	M	Integer	This attribute is used in signing access requests for preventing spoofing of access requests using CHAP, ARAP or EAP authentication methods. It authenticates this whole RADIUS packet - HMAC-MD5 (Type Identifier

TABLE 6 RADIUS access request attributes (continued)

Attribute	Attribute ID	Presence	Type	Description
				Length Request Authenticator Attributes).
Chargeable User ID	89	M	Integer	This attribute sends a null value during authentication.
Operator-Name	126	M	String	The attribute identifies the owner of the access network by the AAA server. It is encoded as per RFC 5580. NOTE This attribute is included only if the location delivery method is the initial request as specified in RFC 5580.
Location-Information	127	M	String	This is a composite attribute, which provides meta data about the location information. It is encoded as per RFC 5580. NOTE This attribute is included only if the location delivery method is the initial request as specified in RFC 5580.
Location-Data	128	M	String	This attribute contains the actual location information. It is encoded as per RFC 5580. NOTE This attribute is included only if the location delivery method is the initial request as specified in RFC 5580.
Basic-Location-Policy-Rules	129	M	String	This attribute provides the basic privacy policy associated to the location information. It is encoded as per RFC 5580.

TABLE 6 RADIUS access request attributes (continued)

Attribute	Attribute ID	Presence	Type	Description
				<p>NOTE This attribute is included only if this attribute is in the initial request as specified in RFC 5580.</p>
Extended-Location-Policy-Rules	130	M	String	<p>This attribute provides the extended privacy policy for the target whose location is specified. This attribute is sent with the above attribute (basic location policy). It is encoded as per RFC 5580.</p> <p>NOTE This attribute is included only if this attribute is in the initial request as specified in RFC 5580.</p>
Location-Capable	131	M	Integer	<p>This attribute is sent in RADIUS access request during the authentication phase to indicate the AP's capability for providing the location. Encoded as per RFC 5580.</p> <p>NOTE This attribute is included only if this attribute is in the initial request as specified in RFC 5580.</p>

RADIUS Access Challenge [EAP Request (RAND, MAC)]

The table lists the attribute details of messages sent by the AAA to the controller, which are forwarded to the RADIUS client (access point).

TABLE 7 RADIUS access challenge attributes

Attribute	Attribute ID	Presence	Type	Description
State	24	O	Integer	This attribute is sent by the server to the client in an access-challenge message and must be sent unmodified from the client to the server in the new access request message - a reply to that challenge, if any.
Proxy-State	33	C	Integer	This attribute is available to be sent by a proxy server (controller)

TABLE 7 RADIUS access challenge attributes (continued)

Attribute	Attribute ID	Presence	Type	Description
				to another server (AAA server) when forwarding an access request, accounting request (start, stop or interim) and must be returned unmodified in the access accept, access reject, access challenge and accounting response.
EAP Message	79	M	Integer	This attribute encapsulates Extensible Authentication Protocol (EAP) packets, which allows NAS to authenticate dial-in users via EAP, without having to understand the EAP protocol (EAP payload, EAP-SIM or EAP-AKA).
Message Authenticator	80	M	Integer	This attribute is used in signing access requests for preventing spoofing of access requests using CHAP, ARAP or EAP authentication methods. It authenticates this whole RADIUS packet - HMAC-MD5 (Type Identifier Length Request Authenticator Attributes).
Chargeable User ID	89	M	Integer	This attribute sends a null value during authentication.
Location-Information	127	C	Octets	This is a composite attribute, which provides meta data about the location information. It is encoded as per RFC 5580. NOTE This attribute is included only if the location information is the initial request, as specified in RFC 5580.
Location-Data	128	C	Octets	This attribute contains the actual location information. It is encoded as per RFC 5580. NOTE This attribute is included only if it is in the initial request as specified in RFC 5580.
Basic-Location-Policy-Rules	129	C	Octets	This attribute provides the basic privacy policy associated to the location information. It is encoded as per RFC 5580.

TABLE 7 RADIUS access challenge attributes (continued)

Attribute	Attribute ID	Presence	Type	Description
				<p>NOTE This attribute is included only if it is in the initial request as specified in RFC 5580.</p>
Extended-Location-Policy-Rules	130	C	Octets	<p>This attribute provides the extended privacy policy for the target whose location is specified. This attribute is sent with the above attribute (basic location policy). It is encoded as per RFC 5580.</p> <p>NOTE This attribute is included only if it is in the initial request as specified in RFC 5580.</p>

RADIUS Access Request [EAP Response (SRES)]

The table lists the attribute details of messages sent by the controller to the AAA server.

TABLE 8 RADIUS access request attributes

Attribute	Attribute ID	Presence	Type	Description
User-Name	1	M	String	Indicates the name of the user to be authenticated.
User-Password	2	C	String	This attribute indicates the password of the user to be authenticated. It is mandatory for PAP authentication.
CHAP-Password	3	C	String	This attribute indicates the value provided by a CHAP user in response to the access-challenge. It is mandatory for CHAP authentication.
NAS-IP-Address	4	C	Integer	This attribute is the IP address of the AP which is serving the station or controller's control IP address, controller's management IP address and user defined value.
NAS-Port	5	O	Integer	This attribute indicates the physical port number of the NAS which authenticates the user. The controller uses the association ID for the STA in the AP to represent this.
Service-Type	6	O	Integer	Indicates the type of service based on the user request or the type of service to be provided.
Framed MTU	12	O	Integer	Indicates the Maximum Transmission Unit (MTU) to be configured for the user, when it is not negotiated by some other means.

TABLE 8 RADIUS access request attributes (continued)

Attribute	Attribute ID	Presence	Type	Description
State	24	O	Integer	This attribute is sent by the server to the client in an access-challenge message and must be sent unmodified from the client to the server in the new access request message - a reply to that challenge, if any.
Vendor-Specific	26	C	Integer	Vendor ID: Ruckus:25053 VSA: Ruckus-WLan-ID (4) VSA Length: 6 Reports the associated WLANs ID. Ruckus VSA is received only from Ruckus AP. It is optional for 3rd party APs.
Vendor-Specific	26	C	Integer	Reports the control plane IP address. Ruckus VSAs are received from Ruckus APs only. It is optional for 3rd party APs.
Vendor-Specific	26	C	Integer	Vendor ID: Ruckus:25053 VSA: Ruckus-SCG-DBLADE-IP (8) VSA Length: 6 Reports the data plane IP address. Ruckus VSAs are received from Ruckus APs only. It is optional for 3rd party APs.
Vendor-Specific	26	C	String	Vendor ID: Ruckus:25053 VSA: Ruckus-SSID (3) VSA Length: Variable Reports the associated WLANs SSID in access request and accounting packet. Ruckus VSAs are received from Ruckus APs only. It is optional for 3rd party APs.
Vendor-Specific	26	C	String	Vendor ID: Ruckus:25053 VSA: Ruckus-Location (5) VSA Length: Variable Reports the device location for this AP. This is a configurable value in the device location setting. Ruckus VSA is received only from Ruckus AP. It is optional for 3rd party APs.
Called Station ID	30	O	Integer	This attribute allows NAS to send the ID (BSSID), which is called by the user. It is MAC of the AP. It supports 2 types of values, namely BSSID:SSID, where BSSID is the MAC address of the WLAN on AP. The second value is AP-MAC:SSID, where AP-MAC is the MAC address of the AP. The letters in the MAC address are in uppercase. For example: 11-22-33-AA-BB-CC:SSID.
Calling Station ID	31	M	Integer	This attribute allows NAS to send the ID (UE MAC), which indicates as to who is calling this server. The value supported is STA's MAC address where the letters in the MAC address are in uppercase. For example: 11-22-33-AA-BB-CC.
NAS-Identifier	32	C	Integer	NAS-IP-Address or NAS-Identifier attribute is mandatory in received messages. It supports 3 types of values, namely BSSID (MAC address of the WLAN on AP), AP-

TABLE 8 RADIUS access request attributes (continued)

Attribute	Attribute ID	Presence	Type	Description
				MAC (MAC address of AP) and user defined address (maximum length of 62).
Proxy-State	33	O	Integer	This attribute is available to be sent by a proxy server (controller) to another server (AAA server) when forwarding an access request, accounting request (start, stop or interim) and must be returned unmodified in the access accept, access reject, access challenge and accounting response.
Acct-Session-ID	44	M	Integer	This attribute is a unique accounting identity to facilitate easy matching of start, interim and stop records in a log file. The start, interim and stop records for a given session must have the same Acct-Session-ID.
NAS-Port-Type	61	M	Integer	Indicates the physical port type of NAS, which authenticates the user.
Connect-Info	77	O	Integer	This attribute is sent from the NAS to indicate the nature of the user's connection.
EAP Message	79	M	Integer	This attribute encapsulates Extensible Authentication Protocol (EAP) packets, which allows NAS to authenticate dial-in users via EAP, without having to understand the EAP protocol (EAP payload, EAP-SIM or EAP-AKA).
Message Authenticator	80	M	Integer	This attribute is used in signing access requests for preventing spoofing of access requests using CHAP, ARAP or EAP authentication methods. It authenticates this whole RADIUS packet - HMAC-MD5 (Type Identifier Length Request Authenticator Attributes).
Chargeable User ID	89	M	Integer	This attribute sends a null value during authentication.

RADIUS Access Accept [EAP Success (MSK)]

The table lists the attribute details of messages sent by AAA to the controller, which is forwarded to the RADIUS client (access point) upon successful service authorization (see the next two messages).

TABLE 9 RADIUS access accept attributes

Attribute	Attribute ID	Presence	Type	Description
User-Name	1	O	String	Indicates the name of the user to be authenticated
Class	25	O	Integer	This attribute is sent by the server in access accept and client should include this attribute in accounting request without modification.

TABLE 9 RADIUS access accept attributes (continued)

Attribute	Attribute ID	Presence	Type	Description
ChargeableUser ID	89	C	Integer	This attribute is MSISDN or any chargeable user identity returned by the AAA server. This attribute is mandatory for TTG sessions only.
Vendor-Specific	26	O	String	Vendor ID: 3GPP: 10415 VSA: 3GPP-GPRS-Negotiated-QoS-Profile (5) VSA Length: Variable This attribute carries the QoS value from AAA server. QoS from AAA is received from Ruckus defined VSA or from 3GPP defined VSA (3GPP-GPRS-Negotiated-QoS Profile).
Vendor-Specific	26	O	Integer	Vendor ID: WISPr: 14122 VSA: WISPr-Bandwidth-Max-UP (7) VSA Length: Variable The attribute contains the maximum uplink value in bits per second.
Vendor-Specific	26	O	Integer	Vendor ID: WISPr: 14122 VSA: WISPr-Bandwidth-Max-DOWN (8) VSA Length: Variable The attribute contains the maximum downlink value in bits per second.
Vendor-Specific	26	C	Charging characteristics	Vendor ID:Ruckus:25053 VSA: Ruckus-Charging-Charac (118) VSA Length: 4 Charging characteristics value, Octets are encoded according to TS 3GPP 32.215. This attribute carries the charging characteristics value, which is received from the AAA server.
Vendor-Specific	26	C	String	Vendor ID:Ruckus:25053 VSA: Ruckus-IMSI (102) VSA Length: Variable BCD encoded IMSI of the subscriber.
Session-Timeout	27	O	Integer	This attribute sets the maximum number of seconds of service to be provided to the user before session termination.

TABLE 9 RADIUS access accept attributes (continued)

Attribute	Attribute ID	Presence	Type	Description
Idle-Timeout	28	O	Integer	It sets the maximum number of consecutive seconds of idle connection allowed to the user, before the session gets terminated.
Termination-Action	29	O	Integer	This attribute indicates the action that NAS will take when the specified service completes.
Proxy-State	33	M	Integer	This attribute is available to be sent by a proxy server (controller) to another server (AAA server) when forwarding an access request, accounting request (start, stop or interim) and must be returned unmodified in the access accept, access reject, access challenge and accounting response.
Tunnel-Type	64	C	Integer	This attribute indicates the tunnel type for the access point. For example, tunnel type 13 is for VLAN.
Tunnel-Medium-Type	65	C	Integer	This attribute indicates the tunnel medium type for the access point. For example, tunnel type 06 is for IEEE_802.
EAP Message	79	M	Integer	This attribute encapsulates Extensible Authentication Protocol (EAP) packets, which allows NAS to authenticate dial-in users via EAP, without having to understand the EAP protocol (EAP payload, EAP-SIM or EAP-AKA).
Message Authenticator	80	M	Integer	This attribute is used in signing access requests for preventing spoofing of access requests using CHAP, ARAP or EAP authentication methods. It authenticates this whole RADIUS packet - HMAC-MD5 (Type Identifier Length Request Authenticator Attributes).
Tunnel-Private-Group-ID	81	C	String	This attribute contains the dynamic VLAN ID as configured in the authentication profile.
Accounting-Interim-Interval	85	O	Integer	Indicates the number of seconds between each interim update for this specific session. If the value is blank, the configured default value is used as the accounting interim interval.
Chargeable User ID	89	M	Integer	This attribute sends a null value during authentication.
Vendor-Specific	26	C	Integer	Vendor ID:Ruckus:25053

TABLE 9 RADIUS access accept attributes (continued)

Attribute	Attribute ID	Presence	Type	Description
				VSA: Ruckus-Acct-Status (126) VSA Length: 4 Acct Stat is true(1) or false(0). The controller sever uses this attribute on the access accept to indicate if the authenticator needs to send the accounting start for the current/specified client.
Vendor-Specific	26	O	Integer	Vendor ID: Microsoft: 311 VSA: MS-MPPE-Send-Key (16) VSA Length: Variable This attribute contains a session key used by Microsoft Point-to-Point Encryption Protocol (MPPE).
Vendor-Specific	26	O	Integer	Vendor ID: Microsoft: 311 VSA: MS-MPPE-Recv-Key (17) VSA Length: Variable This attribute contains a session key used by the Microsoft Point-to-Point Encryption Protocol (MPPE).
Vendor-Specific	26	C	APN-NI	Vendor ID: Ruckus:25053 VSA: Ruckus-APN-NI (104) VSA Length: Variable This attribute carries the APN subscribed by the user. It contains only the network identifier (NI), which is part of the APN. The operator identifier part is stored separately in Ruckus-APN-OI.
Vendor-Specific	26	C	Integer	Vendor ID: Ruckus:25053 VSA: Ruckus-Session-Type(125) VSA Length: 6 Session type - TTG (2), Local-Breakout(3), Local-Breakout-AP(4), L3GRE (5), L2GRE (6), QinQL3 (7), PMIP (8). The controller server uses this attribute on the access -accept to indicate the forward policy of the specific UE.
Basic-Location-Policy-Rules	129	M	String	This attribute provides the basic privacy policy associated to the location information. It is encoded as per RFC 5580.

TABLE 9 RADIUS access accept attributes (continued)

Attribute	Attribute ID	Presence	Type	Description
				<p>NOTE This attribute is expected from the AAA server in the initial request location delivery method as mentioned in RFC 5580.</p>
Extended-Location-Policy-Rules	130	M	String	<p>This attribute provides the extended privacy policy for the target whose location is specified. This attribute is sent with the above attribute (basic location policy). It is encoded as per RFC 5580.</p> <p>NOTE This attribute is expected from the AAA server in the initial request location delivery method as mentioned in RFC 5580.</p>
Requested-Location-Info	132	M	Integer	<p>This attribute is only used in messages sent by the AAA server towards the AP. Using this attribute the AAA server indicates its request for location information. Encoded as per RFC 5580.</p> <p>NOTE This attribute is expected from the AAA server in the initial request location delivery method as mentioned in RFC 5580.</p>

EAP Full Authentication Overview

This reference guide describes the interface between the controller and the AAA (Authentication, Authorization and Accounting) server. The RADIUS protocol is used for interfacing between Access Points (AP) and controller as well as between the controller and a third party AAA server. The controller acts as a RADIUS proxy for authentication and authorization. This guide also describes the message flow between the controller and AAA for EAP based full authentication, authorization and accounting in the following sections. EAP-SIM is used as EAP message payload type but can be replaced with EAP-AKA without affecting call flows and RADIUS attributes except EAP-Message (79).

The controller supports two different call flows for authentication and authorization:

- A 3GPP standard based solution, where authentication and service authorization are performed separately.
- A proprietary solution where authentication and authorization are combined. This guide lists all the interface messages and RADIUS VSAs used between the controller and AAA.

NOTE

This guide does not provide design details of either the AAA server or the controller to handle interface requirements.

NOTE

Refer to [AP Roaming Scenarios Overview](#) on page 121 appendix for various scenario cases.

NOTE

Refer to the appendix [Use Case Scenarios](#) on page 125 for flow details on NAS IP, accounting session identifier and filter identifier.

EAP - Full Authentication – 3GPP Solution

In this call flow, EAP-SIM authentication is performed first. When the controller (acting as an AAA proxy) receives access accept from the AAA server, a separate access request is sent back to the AAA server to process a service authorization. The figure shows the detailed call flow.

FIGURE 2 3GPP based solution sequence diagram

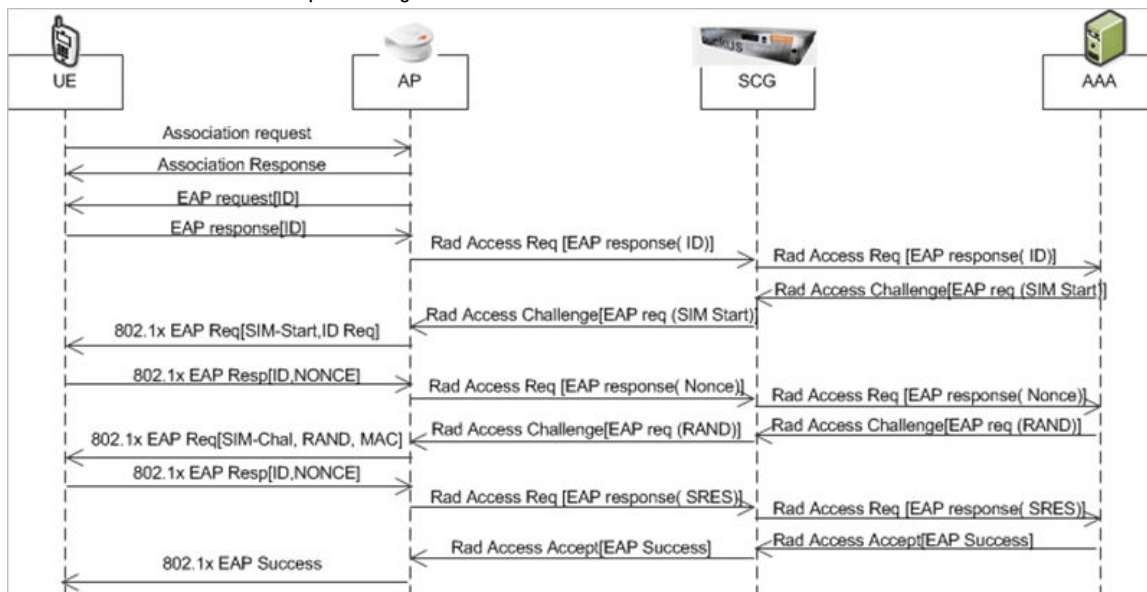

This section covers:

- [RADIUS Access Request \[ID\]](#) on page 32
- [RADIUS Access Challenge \[EAP Request \(SIM Start\)\]](#) on page 35
- [RADIUS Access Request \[EAP Response \(NONCE_MT\)\]](#) on page 36
- [RADIUS Access Challenge \[EAP Request \(RAND, MAC\)\]](#) on page 41
- [RADIUS Access Request \[EAP Response \(SRES\)\]](#) on page 43
- [RADIUS Access Accept \[EAP Success \(MSK\)\]](#) on page 46

EAP Full Authentication

EAP - Full Authentication – 3GPP Solution

- [Authorization Access Request](#) on page 51
- [Authorization Access Accept](#) on page 52

RADIUS Access Request [ID]

The table lists the attribute details of the first message sent by the controller to AAA.

TABLE 10 RADIUS access request attributes

Attribute	Attribute ID	Presence	Type	Description
User-Name	1	M	String	Indicates the name of the user for authentication.
NAS-IP-Address	4	C	Integer	This attribute is the IP address of the AP which is serving the station or controller's control IP address, controller's management IP address and user defined value.
NAS-Port	5	O	Integer	This attribute indicates the physical port number of the NAS which authenticates the user. The controller uses the association ID for the STA in the AP to represent this.
Service-Type	6	O	Integer	Indicates the type of service, which is based on the user request or the type of service to be provided.
Framed MTU	12	O	Integer	Indicates the Maximum Transmission Unit (MTU) to be configured for the user, when it is not negotiated by some other means.
Vendor-Specific	26	C	Integer	Vendor ID: Ruckus:25053 VSA: Ruckus-WLAN-ID (4) VSA Length: 6 Reports the associated WLANs ID. Ruckus VSAs are received from Ruckus APs only. It is optional for 3rd party APs.
Vendor-Specific	26	C	Integer	Vendor ID: Ruckus:25053 VSA: Ruckus-SCG-CBLADE-IP (7) VSA Length: 6 Reports the control plane IP address. Ruckus VSAs are received from Ruckus APs only. It is optional for 3rd party APs.
Vendor-Specific	26	C	Integer	Vendor ID: Ruckus:25053 VSA: Ruckus-SCG-DBLADE-IP (8) VSA Length: 6 Reports the data plane IP address. Ruckus VSAs are received from Ruckus APs only. It is optional for 3rd party APs.
Vendor-Specific	26	C	String	Vendor ID: Ruckus:25053 VSA: Ruckus-SSID (3) VSA Length: Variable Reports the associated WLANs SSID in access request and accounting packet. Ruckus VSAs are received from Ruckus APs only. It is optional for 3rd party APs. ◆
Vendor-Specific	26	C	String	Vendor ID: Ruckus:25053 VSA: Ruckus-Location (5) VSA Length:

TABLE 10 RADIUS access request attributes (continued)

Attribute	Attribute ID	Presence	Type	Description
				Variable Reports the device location for this AP. This is a configurable value in the device location setting. Ruckus VSA is received only from Ruckus AP. It is optional for 3rd party APs.
Called Station ID	30	O	String	This attribute allows NAS to send the ID (BSSID), which is called by the user. It is MAC of the AP. It supports 2 types of values, namely BSSID:SSID, where BSSID is the MAC address of the WLAN on AP. The second value is AP-MAC:SSID, where AP-MAC is the MAC address of the AP. The letters in the MAC address are in uppercase. For example: 11-22-33-AA-BB-CC:SSID.
Calling Station ID	31	M	String	Allows NAS to send the ID (UE MAC), which indicates as to who is calling this server.
NAS-Identifier	32	C	String	NAS-IP-Address or NAS-Identifier attribute is mandatory in received messages. It supports 3 types of values, namely BSSID (MAC address of the WLAN on AP), AP-MAC (MAC address of AP) and user defined address (maximum length of 62).
Proxy-State	33	O	Octets	This attribute is available to be sent by a proxy server (controller) to another server (AAA server) when forwarding an access request, accounting request (start, stop or interim) and must be returned unmodified in the access accept, access-reject, access-challenge and accounting response.
Acct-Session-ID	44	M	String	This attribute is a unique accounting identity to facilitate easy matching of start, interim and stop records in a log file. The start, interim and stop records for a given session must have the same Acct-Session-ID.
NAS-Port-Type	61	M	Integer	Indicates the physical port type of NAS, which authenticates the user.
Connect-Info	77	O	String	This attribute is sent from the NAS to indicate the nature of the user's connection.
EAP Message	79	M	Octets	This attribute encapsulates Extensible Authentication Protocol (EAP) packets, which allows NAS to authenticate dial-in users via EAP, without having to understand the EAP protocol (EAP payload, EAP-SIM or EAP-AKA)
Message Authenticator	80	M	Octets	This attribute is used in signing access requests for preventing spoofing of access requests using CHAP, ARAP or EAP authentication methods. It authenticates this whole RADIUS packet - HMAC-MD5 (Type Identifier

EAP Full Authentication

EAP - Full Authentication – 3GPP Solution

TABLE 10 RADIUS access request attributes (continued)

Attribute	Attribute ID	Presence	Type	Description
				Length Request Authenticator Attributes).
Chargeable User ID	89	M	String	This attribute sends a null value during authentication.
Operator-Name	126	C	String	The attribute identifies the owner of the access network by the AAA server. It is encoded as per RFC 5580. NOTE This attribute is included only if the location delivery method is Out of Band as specified in RFC 5580.
Location-Information	127	C	Octets	This is a composite attribute, which provides meta data about the location information. It is encoded as per RFC 5580. NOTE This attribute is included only if the location delivery method is Out of Band as specified in RFC 5580.
Location-Data	128	C	Octets	This attribute contains the actual location information. It is encoded as per RFC 5580. NOTE This attribute is included only if the location delivery method is Out of Band as specified in RFC 5580.
Basic-Location-Policy-Rules	129	C	Octets	This attribute provides the basic privacy policy associated to the location information. It is encoded as per RFC 5580. NOTE This attribute is included only if the location delivery method is Out of Band as specified in RFC 5580.
Extended-Location-Policy-Rules	130	C	Octets	This attribute provides the extended privacy policy for the target whose location is specified. This attribute is sent with the above attribute (basic location policy). It is encoded as per RFC 5580. NOTE This attribute is included only if the location delivery method is Out of Band as specified in RFC 5580.

TABLE 10 RADIUS access request attributes (continued)

Attribute	Attribute ID	Presence	Type	Description
Location-Capable	131	C	Integer	<p>This attribute is sent in RADIUS access request during the authentication phase to indicate the AP's capability for providing the location. Encoded as per RFC 5580.</p> <p>NOTE This attribute is included only if the location delivery method is not Out of Band as specified in RFC 5580.</p>

RADIUS Access Challenge [EAP Request (SIM Start)]

The table lists the attribute details of the messages sent by the AAA server to the controller and forwarded to the RADIUS client (NAS).

TABLE 11 RADIUS access challenge attributes

Attribute	Attribute ID	Presence	Type	Description
State	24	O	String	This attribute is sent by the server to the client in an access-challenge message and must be sent unmodified from the client to the server in the new access request message - a reply to that challenge, if any.
Proxy-State	33	O	Octets	This attribute is available to be sent by a proxy server (controller) to another server (AAA server) when forwarding an access request, accounting request (start, stop or interim) and must be returned unmodified in the access accept, access-reject, access-challenge and accounting response.
EAP Message	79	M	Octets	This attribute encapsulates Extensible Authentication Protocol (EAP) packets, which allows NAS to authenticate dial-in users via EAP, without having to understand the EAP protocol (EAP payload, EAP-SIM or EAP-AKA).
Message Authenticator	80	M	String	This attribute is used for signing access request for preventing spoofing of access request using CHAP, ARAP or EAP authentication methods. It authenticates this whole RADIUS packet - HMAC-MD5 (Type Identifier Length Request Authenticator Attributes).
Chargeable User ID	89	O	Octets	This attribute sends a null value during authentication.

EAP Full Authentication

EAP - Full Authentication – 3GPP Solution

TABLE 11 RADIUS access challenge attributes (continued)

Attribute	Attribute ID	Presence	Type	Description
Basic-Location-Policy-Rules	129	C	Octets	<p>This attribute provides the basic privacy policy associated to the location information. It is encoded as per RFC 5580.</p> <p>NOTE This attribute is expected from the AAA server in the initial request location delivery method as mentioned in RFC 5580.</p>
Extended-Location-Policy-Rules	130	C	Octets	<p>This attribute provides the extended privacy policy for the target whose location is specified. This attribute is sent with the above attribute (basic location policy). It is encoded as per RFC 5580.</p> <p>NOTE This attribute is expected from the AAA server in the initial request location delivery method as mentioned in RFC 5580.</p>
Requested-Location-Info	132	M	Integer	<p>This attribute is only used in messages sent by the AAA server towards the AP. Using this attribute the AAA server indicates its request for location information. Encoded as per RFC 5580.</p> <p>NOTE This attribute is expected from the AAA server in the initial request location delivery method mentioned in RFC 5580.</p>

RADIUS Access Request [EAP Response (NONCE_MT)]

The table lists the attribute details for messages sent by the controller to the AAA server (response received from UE).

TABLE 12 RADIUS access request attributes

Attribute	Attribute ID	Presence	Type	Description
User-Name	1	M	String	Indicates the name of the user for authentication.

TABLE 12 RADIUS access request attributes (continued)

Attribute	Attribute ID	Presence	Type	Description
User-Password	2	C	String	This attribute indicates the password of the user to be authenticated. It is mandatory for PAP authentication.
CHAP-Password	3	C	String	This attribute indicates the value provided by a CHAP user in response to the access-challenge. It is mandatory for CHAP authentication.
NAS-IP-Address	4	C	Integer	This attribute is the IP address of the AP which is serving the station or controller's control IP address, controller's management IP address and user defined value.
NAS-Port	5	O	Integer	This attribute indicates the physical port number of the NAS which authenticates the user. The controller uses the association ID for the STA in the AP to represent this.
Service-Type	6	O	Integer	Indicates the type of service based on the user request or the type of service to be provided.
Framed MTU	12	O	Integer	Indicates the Maximum Transmission Unit (MTU) to be configured for the user, when it is not negotiated by some other means.
State	24	O	String	This attribute is sent by the server to the client in an access-challenge message and must be sent unmodified from the client to the server in the new access request message - a reply to that challenge, if any.
Vendor-Specific	26	C	Integer	Vendor ID: Ruckus: 25053 VSA: Ruckus-SCG-CBLADE-IP (7) VSA Length: 6 Reports the control plane IP address. Ruckus VSAs are received from Ruckus APs only. It is optional for 3rd party APs.
Vendor-Specific	26	C	Integer	Vendor ID: Ruckus: 25053 VSA: Ruckus-

EAP Full Authentication

EAP - Full Authentication – 3GPP Solution

TABLE 12 RADIUS access request attributes (continued)

Attribute	Attribute ID	Presence	Type	Description
				SCG-DBLADE-IP (8) VSA Length: 6 Reports the data plane IP address. Ruckus VSAs are received from Ruckus APs only. It is optional for 3rd party APs.
Vendor-Specific	26	C	Integer	Vendor ID: Ruckus: 25053 VSA: Ruckus-Location(5) VSA Length: Variable Reports the device location for this AP. This is a configurable value in the device location setting. Ruckus VSA is received only from Ruckus AP. It is optional for 3rd party APs. ◆
Vendor-Specific	26	C	String	Vendor ID: Ruckus: 25053 VSA: Ruckus-SSID (3) VSA Length: Variable Reports the associated WLANs SSID in access request and accounting packet. Ruckus VSAs are received from Ruckus APs only. It is optional for 3rd party APs.
Called Station ID	30	O	String	This attribute allows NAS to send the ID (BSSID), which is called by the user. It is MAC of the AP. It supports 2 types of values, namely BSSID:SSID, where BSSID is the MAC address of the WLAN on AP. The second value is AP-MAC:SSID, where AP-MAC is the MAC address of the AP. The letters in the MAC address are in uppercase. For example: 11-22-33-AA-BB-CC:SSID.
Calling Station ID	31	M	String	Allows NAS to send the ID (UE MAC), which indicates as to who is calling this server.
NAS-Identifier	32	C	String	NAS-IP-Address or NAS-Identifier attribute is mandatory in received messages. It supports 3 types of values, namely BSSID (MAC address of

TABLE 12 RADIUS access request attributes (continued)

Attribute	Attribute ID	Presence	Type	Description
				the WLAN on AP), AP-MAC (MAC address of AP) and user defined address (maximum length of 62).
Proxy-State	33	O	Octets	This attribute is available to be sent by a proxy server (controller) to another server (AAA server) when forwarding an access request, accounting request (start, stop or interim) and must be returned unmodified in the access accept, access-reject, access-challenge and accounting response.
Acct-Session-ID	44	M	String	This attribute is a unique accounting identity to facilitate easy matching of start, interim and stop records in a log file. The start, interim and stop records for a given session must have the same Acct-Session-ID.
NAS-Port-Type	61	M	Integer	Indicates the physical port type of NAS, which authenticates the user.
Connect-Info	77	O	String	This attribute is sent from the NAS to indicate the nature of the user's connection.
EAP Message	79	M	Octets	This attribute encapsulates Extensible Authentication Protocol (EAP) packets, which allows NAS to authenticate dial-in users via EAP, without having to understand the EAP protocol (EAP payload, EAP-SIM or EAP-AKA).
Message Authenticator	80	M	Octets	This attribute is used in signing access requests for preventing spoofing of access requests using CHAP, ARAP or EAP authentication methods. It authenticates this whole RADIUS packet - HMAC-MD5 (Type Identifier Length Request Authenticator Attributes).

EAP Full Authentication

EAP - Full Authentication – 3GPP Solution

TABLE 12 RADIUS access request attributes (continued)

Attribute	Attribute ID	Presence	Type	Description
Chargeable User ID	89	M	String	This attribute sends a null value during authentication.
Operator-Name	126	C	String	The attribute identifies the owner of the access network by the AAA server. It is encoded as per RFC 5580. NOTE This attribute is included only if the operator name is in the initial request, as specified in RFC 5580.
Location-Information	127	C	Octets	This is a composite attribute, which provides meta data about the location information. It is encoded as per RFC 5580. NOTE This attribute is included only if the location information is the initial request, as specified in RFC 5580.
Location-Data	128	C	Octets	This attribute contains the actual location information. It is encoded as per RFC 5580. NOTE This attribute is included only if it is in the initial request as specified in RFC 5580.
Basic-Location-Policy-Rules	129	C	Octets	This attribute provides the basic privacy policy associated to the location information. It is encoded as per RFC 5580.

TABLE 12 RADIUS access request attributes (continued)

Attribute	Attribute ID	Presence	Type	Description
				<p>NOTE This attribute is included only if it is in the initial request as specified in RFC 5580.</p>
Extended-Location-Policy-Rules	130	C	Octets	<p>This attribute provides the extended privacy policy for the target whose location is specified. This attribute is sent with the above attribute (basic location policy). It is encoded as per RFC 5580.</p> <p>NOTE This attribute is included only if it is in the initial request as specified in RFC 5580.</p>

RADIUS Access Challenge [EAP Request (RAND, MAC)]

The table lists the attribute details for messages sent by the AAA server to the controller and forwarded to the RADIUS client NAS.

TABLE 13 RADIUS access challenge attributes

Attribute	Attribute ID	Presence	Type	Description
State	24	O	String	This attribute is sent by the server to the client in an access-challenge message and must be sent unmodified from the client to the server in the new access request message - a reply to that challenge, if any.
Proxy-State	33	O	Octets	This attribute is available to be sent by a proxy server (controller) to another server (AAA server) when forwarding an access request, accounting request (start, stop or interim) and <u>must</u> be returned unmodified in the access accept, access-reject, access-challenge and accounting response.
EAP Message	79	M	Octets	This attribute encapsulates Extensible Authentication Protocol (EAP) packets, which allows NAS to authenticate dial-in users via EAP, without having to understand the EAP protocol (EAP payload, EAP-SIM or EAP-AKA).

EAP Full Authentication

EAP - Full Authentication – 3GPP Solution

TABLE 13 RADIUS access challenge attributes (continued)

Attribute	Attribute ID	Presence	Type	Description
Message Authenticator	80	M	Octets	This attribute is used in signing access requests for preventing spoofing of access requests using CHAP, ARAP or EAP authentication methods. It authenticates this whole RADIUS packet - HMAC-MD5 (Type Identifier Length Request Authenticator Attributes).
Location-Information	127	C	Octets	This is a composite attribute, which provides meta data about the location information. It is encoded as per RFC 5580. NOTE This attribute is included only if the location information is the initial request, as specified in RFC 5580.
Location-Data	128	C	Octets	This attribute contains the actual location information. It is encoded as per RFC 5580. NOTE This attribute is included only if it is in the initial request as specified in RFC 5580.
Basic-Location-Policy-Rules	129	C	Octets	This attribute provides the basic privacy policy associated to the location information. It is encoded as per RFC 5580. NOTE This attribute is included only if it is in the initial request as specified in RFC 5580.
Extended-Location-Policy-Rules	130	C	Octets	This attribute provides the extended privacy policy for the target whose location is specified. This attribute is sent with the above attribute (basic location policy). It is encoded as per RFC 5580. NOTE This attribute is included only if it is in the initial request as specified in RFC 5580.

RADIUS Access Request [EAP Response (SRES)]

The table lists the attribute details for messages sent by controller to AAA.

TABLE 14 RADIUS access accept messages

Attribute	Attribute ID	Presence	Type	Description
User-Name	1	M	String	Indicates the name of the user for authentication.
User-Password	2	C	String	This attribute indicates the password of the user to be authenticated. It is mandatory for PAP authentication.
CHAP-Password	3	C	String	This attribute indicates the value provided by a CHAP user in response to the access-challenge. It is mandatory for CHAP authentication.
NAS-IP-Address	4	C	Integer	This attribute is the IP address of the AP which is serving the station or controller's control IP address, controller's management IP address and user defined value.
NAS-Port	5	O	Integer	This attribute indicates the physical port number of the NAS which authenticates the user. The controller uses the association ID for the STA in the AP to represent this.
Service-Type	6	O	Integer	Indicates the type of service based on the user request or the type of service to be provided.
Framed MTU	12	O	Integer	Indicates the Maximum Transmission Unit (MTU) to be configured for the user, when it is not negotiated by some other means.
State	24	O	String	This attribute is sent by the server to the client in an access-challenge message and must be sent unmodified from the client to the server in the new access request message - a reply to that challenge, if any.
Vendor-Specific	26	C	Integer	Vendor ID: Ruckus:25053. VSA: Ruckus-SCG-CBLADE-IP (7) VSA Length: 6 Reports the control plane IP address. Ruckus VSAs are received from Ruckus APs only. It is optional for 3rd party APs.
Vendor-Specific	26	C	Integer	Vendor ID: Ruckus:25053. VSA: Ruckus-SCG-DBLADE-IP (8) VSA Length. Reports the

EAP Full Authentication

EAP - Full Authentication – 3GPP Solution

TABLE 14 RADIUS access accept messages (continued)

Attribute	Attribute ID	Presence	Type	Description
				data plane IP address. Note: Ruckus VSAs are received from Ruckus APs only. It is optional for 3rd party APs.
Vendor-Specific	26	C	String	Vendor ID: Ruckus:25053. VSA: Ruckus-Location (5) VSA Length: Variable. Reports the device location for this AP. This is a configurable value in the device location setting. Ruckus VSA is received only from Ruckus AP. It is optional for 3rd party APs.
Vendor-Specific	26	C	String	Vendor ID: Ruckus:25053. VSA: Ruckus-SSID (3) VSA Length: Variable. Reports the associated WLANs SSID in access request and accounting packet. Note: Ruckus VSAs are received from Ruckus APs only. It is optional for 3rd party APs.
Calling Station ID	30	O	String	Allows NAS to send the ID (BSSID), which is called by the user. It is MAC of the AP.
Calling Station ID	31	M	String	Allows NAS to send the ID (UE MAC), which indicates as to who is calling this server.
NAS-Identifier	32	C	String	NAS-IP-Address or NAS-Identifier attribute is mandatory in received messages. It supports 3 types of values, namely BSSID (MAC address of the WLAN on AP), AP-MAC (MAC address of AP) and user defined address (maximum length of 62).
Proxy-State	33	O	Octets	This attribute is available to be sent by a proxy server (controller) to another server (AAA server) when forwarding an access request, accounting request (start, stop or interim) and must be returned unmodified in the access accept, access-reject, access-challenge and accounting response.
Acct-Session-ID	44	M	String	This attribute is a unique accounting identity to facilitate easy matching of start, interim and stop records in a log file. The start, interim and stop records for a given session

TABLE 14 RADIUS access accept messages (continued)

Attribute	Attribute ID	Presence	Type	Description
				must have the same Acct-Session-ID.
NAS-Port-Type	61	M	Integer	Indicates the physical port type of NAS, which authenticates the user.
Connect-Info	77	O	String	This attribute is sent from the NAS to indicate the nature of the user's connection.
EAP Message	79	M	Octets	This attribute encapsulates Extensible Authentication Protocol (EAP) packets, which allows NAS to authenticate dial-in users via EAP, without having to understand the EAP protocol (EAP payload, EAP-SIM or EAP-AKA).
Message Authenticator	80	M	Octets	This attribute is used in signing access requests for preventing spoofing of access requests using CHAP, ARAP or EAP authentication methods. It authenticates this whole RADIUS packet - HMAC-MD5 (Type Identifier Length Request Authenticator Attributes).
Chargeable User ID	89	M	String	This attribute sends a null value during authentication.
Location-Information	127	C	Octets	This is a composite attribute, which provides meta data about the location information. It is encoded as per RFC 5580. NOTE This attribute is included only if the location information is in the initial request, as specified in RFC 5580.
Location-Data	128	C	Octets	This attribute contains the actual location information. It is encoded as per RFC 5580. NOTE This attribute is included only if the location data is in the initial request as specified in RFC 5580.

TABLE 14 RADIUS access accept messages (continued)

Attribute	Attribute ID	Presence	Type	Description
Basic-Location-Policy-Rules	129	C	Octets	<p>This attribute provides the basic privacy policy associated to the location information. It is encoded as per RFC 5580.</p> <p>NOTE This attribute is included only if this attribute is in the initial request as specified in RFC 5580.</p>
Extended-Location-Policy-Rules	130	C	Octets	<p>This attribute provides the extended privacy policy for the target whose location is specified. This attribute is sent with the above attribute (basic location policy). It is encoded as per RFC 5580.</p> <p>NOTE This attribute is included only if this attribute is in the initial request as specified in RFC 5580.</p>

RADIUS Access Accept [EAP Success (MSK)]

The table lists the attribute details for message sent by the AAA to the controller, which are forwarded to the RADIUS client (access point) upon successful service authorization (see the next two messages).

TABLE 15 RADIUS access request messages

Attribute	Attribute ID	Presence	Type	Description
User-Name	1	M	String	Indicates the name of the user for authentication.
Class	25	O	String	This attribute is sent by the server in access accept and the client should include this attribute in the accounting request without modification. It includes all the accounting packets (start/interim/stop) without any changes.
Vendor-Specific	26	O	Integer	Vendor ID: WISPr: 14122.

TABLE 15 RADIUS access request messages (continued)

Attribute	Attribute ID	Presence	Type	Description
				VSA: WISPr-Bandwidth-Max-UP (7) VSA Length: Variable. The attribute contains the maximum uplink value in bits per second.
Vendor-Specific	26	O	Integer	Vendor ID: WISPr: 14122. VSA: WISPr-Bandwidth-Max-DOWN (8). VSA Length: Variable. The attribute contains the maximum downlink value in bits per second.
Vendor-Specific	26	M	Integer	Vendor ID: Microsoft 311. VSA: MS-MPPE-Send-Key (16). VSA Length: Variable. This attribute contains a session key used by Microsoft Point-to-Point Encryption Protocol (MPPE).
Vendor-Specific	26	M	Integer	Vendor ID: Microsoft 311. VSA: MS-MPPE-Recv-Key (17). VSA Length: Variable. This attribute contains a session key used by the Microsoft Point-to-Point Encryption Protocol (MPPE).
Vendor-Specific	26	C	String	Vendor ID: Ruckus: 25053. VSA: Ruckus-IMSI (102). VSA Length: Variable. BCD encoded IMSI of the subscriber.
Vendor-Specific	26	C	Integer	Vendor ID: Ruckus: 25053. VSA: Ruckus-Session-Type (125). VSA Length: 6. Session Type - TTG (2), Local-Breakout(3), Local-Breakout-AP(4), L3oGRE (5), L2oGRE

EAP Full Authentication

EAP - Full Authentication – 3GPP Solution

TABLE 15 RADIUS access request messages (continued)

Attribute	Attribute ID	Presence	Type	Description
				(6), QinQL3 (7), PMIP (8). The controller server uses this attribute on the access -accept to indicate the forward policy of the specific UE.
Vendor-Specific	26	C	Integer	Vendor ID: Ruckus: 25053. VSA: Ruckus-Acct-Status (126). VSA Length: 6. Acct Stat is true(1) or false(0). The controller server uses this attribute on the access accept to indicate if the authenticator needs to send the accounting start for the current/ specified client.
Session-Timeout	27	O	Integer	This attribute sets the maximum number of seconds of service to be provided to the user before termination of the session.
Idle-Timeout	28	O	Integer	It sets the maximum number of consecutive seconds of idle connection allowed to the user before termination of the session.
Termination-Action	29	O	Integer	Indicates the action that NAS will take when the specified service is completed.
Proxy-State	33	O	Octets	This attribute is available to be sent by a proxy server (controller) to another server (AAA server) when forwarding an access request, accounting request (start, stop or interim) and must be returned unmodified in the access accept, access reject, access challenge and accounting response.

TABLE 15 RADIUS access request messages (continued)

Attribute	Attribute ID	Presence	Type	Description
Tunnel-Type	64	C	Integer	This attribute indicates the tunnel type for the access point. For example, tunnel type 13 is for VLAN.
Tunnel-Medium-Type	65	C	Integer	This attribute indicates the tunnel medium type for the access point. For example, tunnel type 06 is for IEEE_802.
EAP Message	79	M	Octets	This attribute encapsulates Extensible Authentication Protocol (EAP) packets, which allows NAS to authenticate dial-in users via EAP, without having to understand the EAP protocol (EAP payload, EAP-SIM or EAP-AKA).
Message Authenticator	80	M	Octets	This attribute is used in signing access requests for preventing spoofing of access requests using CHAP, ARAP or EAP authentication methods. It authenticates this whole RADIUS packet - HMAC-MD5 (Type Identifier Length Request Authenticator Attributes).
Tunnel-Private-Group-ID	81	C	String	This attribute contains the dynamic VLAN ID as configured in the authentication profile.
Accounting-Interim-Interval	85	O	Integer	Indicates the number of seconds between each interim update for this specific session. If the value is blank, the configured default value is used as the accounting interim interval.
Chargeable User ID	89	C	Integer	This attribute is MSISDN or any chargeable user identity returned by the AAA server. This

EAP Full Authentication

EAP - Full Authentication – 3GPP Solution

TABLE 15 RADIUS access request messages (continued)

Attribute	Attribute ID	Presence	Type	Description
				attribute is mandatory for TTG sessions only.
Basic-Location-Policy-Rules	129	C	Octets	<p>This attribute provides the basic privacy policy associated to the location information. It is encoded as per RFC 5580.</p> <p>NOTE This attribute is expected from the AAA server if the location delivery method is accounting request as specified in RFC 5580.</p>
Extended-Location-Policy-Rules	130	M	String	<p>This attribute provides the extended privacy policy for the target whose location is specified and is sent with the above attribute (basic location policy). It is encoded as per RFC 5580.</p> <p>NOTE This attribute is expected from the AAA server if the location delivery method is accounting request as specified in RFC 5580.</p>
Requested-Location-Info	132	M	Integer	This attribute is only used in messages sent by the AAA server towards the AP. Using

TABLE 15 RADIUS access request messages (continued)

Attribute	Attribute ID	Presence	Type	Description
				<p>this attribute the AAA server indicates its request for location information. Encoded as per RFC 5580.</p> <p>NOTE This attribute is expected from the AAA server if the location delivery method is accounting request as specified in RFC 5580.</p>

Authorization Access Request

The authorization procedure starts after successful authentication only. Messages are initiated from the controller. The table lists the attribute details for messages sent by the controller to the AAA server.

TABLE 16 Authorisation Access request attributes

Attribute	Attribute ID	Presence	Type	Description
User-Name	1	M	String	Indicates the name of the user to be authenticated.
Vendor-Specific	26	C	Integer	Vendor ID: Ruckus VSA: 25053 VSA: Ruckus-SGSN-Number(124) VSA Length: Variable. AAA uses this attribute to populate the MAP update GPRS location. E.164 address of SGSN (controller). Ruckus VSAs are received from Ruckus APs only. It is optional for 3rd party APs.
Vendor-Specific	26	C	String	Vendor ID: Ruckus:25053 VSA: Ruckus-SSID (3) VSA Length: Variable. Reports the associated WLANs SSID in access request and accounting packet. Ruckus VSAs are received from Ruckus APs only. It is optional for 3rd party APs.
Vendor-Specific	26	C	String	Vendor ID: Ruckus:25053 VSA: Ruckus-Location (5) VSA Length: Variable. Reports the device location for this AP. This is a configurable value in the device location setting. Ruckus VSA is

EAP Full Authentication

EAP - Full Authentication – 3GPP Solution

TABLE 16 Authorisation Access request attributes (continued)

Attribute	Attribute ID	Presence	Type	Description
				received only from Ruckus AP. It is optional for 3rd party APs.
NAS-Identifier	32	C	Integer	NAS-IP-Address or NAS-Identifier attribute is mandatory in received messages. It supports 3 types of values, namely BSSID (MAC address of the WLAN on AP), AP-MAC (MAC address of AP) and user defined address (maximum length of 62).
Proxy-State	33	O	Octets	This attribute is available to be sent by a proxy server (controller) to another server (AAA server) when forwarding an access request, accounting request (start, stop or interim) and must be returned unmodified in the access accept, access reject, access challenge and accounting response.
Chargeable User ID	89	M	String	This attribute sends a null value during authentication.

Authorization Access Accept

The authorization procedure starts only after successful authorization, where messages are sent by AAA to the controller. Information received from AAA is used in setting the GTP tunnel towards the GGSN (APN, QoS and Charging Characteristics).

The table lists the attribute details for messages sent by the AAA server to the controller.

TABLE 17 Authorization access accept attributes

Attribute	Attribute ID	Presence	Type	Description
User-Name	1	O	String	Indicates the name of the user for authentication.
Vendor-Specific	26	O	Integer	Vendor ID: WISPr: 14122 VSA: WISPr-Bandwidth-Max-UP (7) VSA Length: Variable. The attribute contains the maximum uplink value in bits per second.
Vendor-Specific	26	O	Integer	Vendor ID: WISPr: 14122 VSA: WISPr-Bandwidth-Max-DOWN (8) VSA Length: Variable. The attribute contains the maximum downlink value in bits per second.
Vendor-Specific	26	O	APN-NI	Vendor ID: Ruckus: 25053 VSA: Ruckus-APN-NI(104) VSA Length: Variable. This attribute carries the APN subscribed by the user. It contains only the network identifier (NI), which is part of the APN. The operator identifier part is stored separately in Ruckus-APN-OI.

TABLE 17 Authorization access accept attributes (continued)

Attribute	Attribute ID	Presence	Type	Description
Vendor-Specific	26	O	String	Vendor ID: 3GPP: 10415 VSA: 3GPP-GPRS-Negotiated-QoS-Profile (5) VSA Length: Variable. This attribute carries the QoS value from AAA server. QoS from AAA is received from Ruckus defined VSA or from 3GPP defined VSA (3GPP-GPRS-Negotiated-QoS Profile).
Vendor-Specific	26	O	Charging characteristics	Vendor ID: Ruckus: 25053 VSA: Ruckus-Charging-Charac (118) VSA Length: 4 Charging characteristics value, octets are encoded according to TS 3GPP 32.215. This attribute carries the charging characteristics value, which is received from the AAA server.
Session-Timeout	27	O	Integer	This attribute de-authenticates the UE when the session time expires.
Proxy-State	33	O	Octets	This attribute is available to be sent by a proxy server (controller) to another server (AAA server) when forwarding an access request, accounting request (start, stop or interim) and must be returned unmodified in the access accept, access reject, access challenge and accounting response.
Accounting-Interim-Interval	85	O	Integer	Indicates the number of seconds between each interim update for this specific session. If the value is blank, the configured default value is used as the accounting interim interval.
Chargeable User ID	89	C	String	This attribute is MSISDN or any chargeable user identity returned by the AAA server. This attribute is mandatory for TTG sessions only.

RADIUS Access Reject

The table lists the attribute details of access reject messages (failure scenarios) sent by the AAA in case of unsuccessful authentication or authorization. The controller can also initiate access reject towards NAS, based on certain use cases.

TABLE 18 RADIUS access reject attributes

Attribute	Attribute ID	Presence	Type	Description
Reply-Message	18	O	Integer	Indicates the text, which could be displayed to the user.
EAP Message	79	C	Octets	This attribute encapsulates Extensible Authentication Protocol (EAP) packets, which allows NAS to authenticate dial-in

EAP Full Authentication
RADIUS Access Reject

TABLE 18 RADIUS access reject attributes (continued)

Attribute	Attribute ID	Presence	Type	Description
				users via EAP, without having to understand the EAP protocol (EAP payload, EAP-SIM or EAP-AKA).
Message Authenticator	80	C	Octets	This attribute is used for signing access requests for preventing spoofing of access requests using CHAP, ARAP or EAP authentication methods. It authenticates this whole RADIUS packet - HMAC-MD5 (Type Identifier Length Request Authenticator Attributes). This attribute is available only for EAP failures.

Hotspot (WISPr) Authentication and Accounting

- Hotspot (WISPr) Authentication and Accounting Overview..... 55
- Hotspot (WISPr) Authentication Request 56
- Hotspot (WISPr) Authentication Response..... 61
- Hotspot (WISPr) Accounting Request [Start]..... 63
- Hotspot (WISPr) Accounting Request [Stop/Interim]..... 67
- Hotspot (WISPr) Accounting Response..... 72

Hotspot (WISPr) Authentication and Accounting Overview

Hotspot (WISPr) authentication starts after a user has entered his or her logon credentials (user name and password) on the subscriber portal logon page. After this, the northbound portal interface initiates an access request message to process a service authorization.

Additional parameters can be provided by the AAA server in the access accept message. These parameters define the limitations and behavior of a specific user, such as session timeout, grace period and idle timeout. The figure below shows the detailed call flow.

FIGURE 3 Hotspot (WISPr) call flow

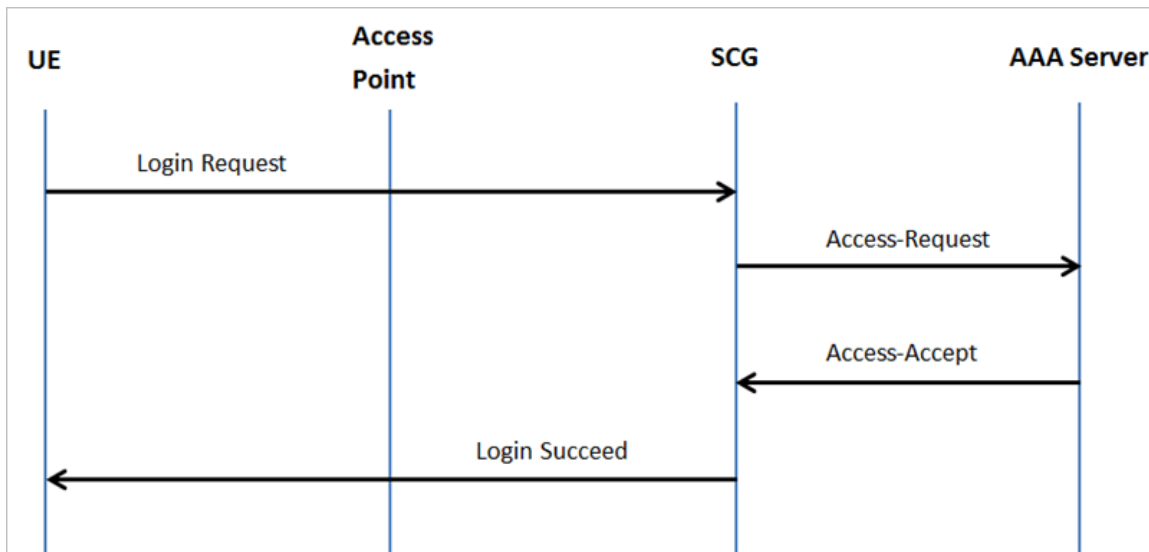

This section covers:

- [Hotspot \(WISPr\) Authentication Request](#) on page 56
- [Hotspot \(WISPr\) Authentication Response](#) on page 61
- [Hotspot \(WISPr\) Accounting Request \[Start\]](#) on page 63

Hotspot (WISPr) Authentication Request

The table lists the attribute details of messages sent by the controller to Hotspot (WISPr).

TABLE 19 Hotspot (WISPr) authentication request attributes

Attribute	Attribute ID	Presence	Type	Description
User-Name	1	M	String	This attribute is the logon user name.
User-Password	2	C	String	This attribute indicates the password of the user to be authenticated. This attribute is mandatory for PAP authentication.
CHAP-Password	3	C	String	Indicates the value provided by a CHAP user in response to the access-challenge. It is mandatory for CHAP authentication.
NAS-IP-Address	4	C	IP Address	This attribute contains the controller management IP address.
Service-Type	6	O	Integer	This attribute has the value 1 (login).
Framed-IP-Address	8	O	IP Address	This attribute is STA's IP address.
Framed MTU	12	O	Integer	Indicates the Maximum Transmission Unit (MTU) to be configured for the user, when it is not negotiated by some other means. NOTE The attribute will not be available if the MTU size is set to auto in the WLAN configuration page of the controller Web interface.
Vendor-Specific	26	O	Integer	Vendor: WISPr Vendor ID: 14122 VSA ID: 1 VSA: WISPr-Location-ID VSA Length: Variable This attribute is a configurable value in the hotspot (WISPr) user interface.
Vendor-Specific	26	O	Integer	Vendor: WISPr Vendor ID: 14122 VSA ID: 2 VSA: WISPr-Location-Name

TABLE 19 Hotspot (WISPr) authentication request attributes (continued)

Attribute	Attribute ID	Presence	Type	Description
				VSA Length: Variable This attribute is a configurable value in the hotspot (WISPr) user interface.
Vendor-Specific	26	O	Integer	Vendor: WISPr Vendor ID: 14122 VSA ID: 3 VSA: WISPr-Logoff-URL VSA Length: Variable This attribute indicates the hotspot (WISPr) service logout URL.
Vendor-Specific	26	O	String	Vendor ID: Ruckus Vendor Type: 3 VSA: Ruckus-Client-Host-name VSA Length: 138 This attribute reports the configured client host name
Vendor-Specific	26	O	String	Vendor ID: Ruckus Vendor Type: 3 VSA: Ruckus-Client-Os-Type VSA ID: 139 This attribute reports the Client OS Type.
Vendor-Specific	26	O	String	Vendor ID: Ruckus Vendor Type: 3 VSA:Ruckus-Client-Os-Class VSA Length: Variable This attribute reports the client OS class.
Vendor-Specific	26	O	String	Vendor ID: WISPr: 25053 Vendor Type: 3 VSA: Ruckus-SSID (3) VSA Length: Variable Reports the associated WLANs SSID in the access request and accounting packet, Ruckus VSA is received only from Ruckus AP.
Vendor-Specific	26	C	Integer	Vendor ID: Ruckus:25053 VSA: Ruckus-Zone-ID (127) VSA Length: 6

TABLE 19 Hotspot (WISPr) authentication request attributes (continued)

Attribute	Attribute ID	Presence	Type	Description
				Reports the zone ID to which the 3rd party AP is associated. This VSA is received only for 3rd party APs.
Called Station ID	30	M	String	This attribute allows NAS to send the ID (BSSID), which is called by the user. It is MAC of the AP. It supports 2 types of values, namely BSSID:SSID, where BSSID is the MAC address of the WLAN on AP. The second value is AP-MAC:SSID, where AP-MAC is the MAC address of the AP. The letters in the MAC address are in uppercase. For example: 11-22-33-AA-BB-CC:SSID.
Calling Station ID	31	M	String	STA's MAC address where the letters in the MAC address are in uppercase. For example, 11-22-33-AA-BB-CC.
NAS-Identifier	32	C	Integer	This attribute contains a string identifying the NAS originating the access request. It supports 3 types of values for BSSID (MAC address of the WLAN on AP). AP-MAC (MAC address of AP) is a user defined attribute where the maximum length is 62. This attribute can also be configured as per the configuration specified on the WLAN configuration page of the controller web interface. This attribute can also be configured as per the configuration specified on the WLAN configuration page of the controller web interface.
Chap-Challenge	60	M	String	This attribute contains the chap challenge sent by NAS to a PPP CHAP user.
NAS-Port-Type	61	O	Integer	This attribute indicates the physical port type of the NAS, which authenticates the user.
Vendor-Specific	26	C	Integer	Vendor ID: Ruckus: 2503 Vendor Type: 9 VSA: VLAN-ID VSA Length: Variable This attribute value is as per the configuration specified on the WLAN configuration page of the controller web interface.

TABLE 19 Hotspot (WISPr) authentication request attributes (continued)

Attribute	Attribute ID	Presence	Type	Description
Operator-Name	126	C	String	<p>The attribute identifies the owner of the access network by the AAA server. It is encoded as per RFC 5580.</p> <p>NOTE This attribute is included in the first access request when the location delivery method is Out of Band. If the location delivery method is the initial request then the subsequent access request is included in this parameter - as specified in RFC 5580.</p>
Location-Information	127	C	Octets	<p>This is a composite attribute, which provides meta data about the location information. It is encoded as per RFC 5580.</p> <p>NOTE This attribute is included in the first access request when the location delivery method is Out of Band. If the location delivery method is the initial request then the subsequent access request is included in this parameter - as specified in RFC 5580.</p>
Location-Data	128	C	Octets	<p>This attribute contains the actual location information. It is encoded as per RFC 5580.</p>

TABLE 19 Hotspot (WISPr) authentication request attributes (continued)

Attribute	Attribute ID	Presence	Type	Description
				<p>NOTE This attribute is included in the first access request when the location delivery method is Out of Band. If the location delivery method is the initial request then the subsequent access request is included in this parameter - as specified in RFC 5580.</p>
Basic-Location-Policy-Rules	129	M	String	<p>This attribute provides the basic privacy policy associated to the location information. It is encoded as per RFC 5580.</p> <p>NOTE This attribute is included in the first access request when the location delivery method is Out of Band. If the location delivery method is the initial request then the subsequent access request is included in this parameter - as specified in RFC 5580.</p>
Extended-Location-Policy-Rules	130	C	Octets	<p>This attribute provides the extended privacy policy for the target whose location is specified. This attribute is sent with the above attribute (<i>basic location policy</i>). It is encoded as per RFC 5580.</p>

TABLE 19 Hotspot (WISPr) authentication request attributes (continued)

Attribute	Attribute ID	Presence	Type	Description
				<p>NOTE This attribute is included in the first access request when the location delivery method is Out of Band. If the location delivery method is the initial request then the subsequent access request is included in this parameter - as specified in RFC 5580.</p>
Location-Capable	131	C	Integer	<p>This attribute is sent in RADIUS access request during the authentication phase to indicate the AP's capability for providing the location. Encoded as per RFC 5580.</p> <p>NOTE This attribute is included only if the location delivery method is the initial request or accounting request as specified in RFC 5580.</p>

Hotspot (WISPr) Authentication Response

The table lists the attribute details of messages sent by the Hotspot (WISPr) module to the controller.

TABLE 20 Hotspot (WISPr) authentication request attributes

Attribute	Attribute ID	Presence	Type	Description
Class	25	O	Integer	This attribute is sent by the server in access accept and the client should include this attribute in the accounting request without any modification.
Vendor-Specific	26	O	Integer	<p>Vendor ID: WISPr: 14122</p> <p>VSA: WISPr-Bandwidth-Max-UP (7)</p> <p>VSA Length: Variable</p> <p>The attribute contains the maximum uplink value in bits per second.</p>

TABLE 20 Hotspot (WISPr) authentication request attributes (continued)

Attribute	Attribute ID	Presence	Type	Description
Vendor-Specific	26	O	Integer	Vendor ID: WISPr: 14122 VSA: WISPr-Bandwidth-Max-DOWN (8) VSA Length: Variable The attribute contains the maximum downlink value in bits per second.
Vendor-Specific	26	O	Integer	Vendor ID: Ruckus: 25053 Vendor Type: 7 VSA: Ruckus-Grace-Period VSA Length: Variable This attribute is the grace period in hotspot (WISPr) WLANs.
Session-Timeout	27	O	Integer	This attribute de-authenticates the UE when the session time expires.
Idle-Timeout	28	O	Integer	This attribute sets the maximum number of consecutive seconds of idle connection allowed to the user before termination of the session.
Accounting-Interim-Interval	85	O	Integer	Indicates the number of seconds between each interim update for this specific session. If the value is blank, the configured default value is used as the accounting interim interval.
Basic-Location-Policy-Rules	129	M	String	This attribute provides the basic privacy policy associated to the location information. It is encoded as per RFC 5580. NOTE This attribute is expected from the AAA server in the initial request location delivery method as mentioned in RFC 5580.
Extended-Location-Policy-Rules	130	C	Octets	This attribute provides the extended privacy policy for the target whose location is specified. This attribute is sent with the above attribute (<i>basic location policy</i>). It is encoded as per RFC 5580.

TABLE 20 Hotspot (WISPr) authentication request attributes (continued)

Attribute	Attribute ID	Presence	Type	Description
				<p>NOTE This attribute is expected from the AAA server in the initial request location delivery method as mentioned in RFC 5580.</p>
Requested-Location-Info	132	M	Integer	<p>This attribute is only used in messages sent by the AAA server towards the AP. Using this attribute the AAA server indicates its request for location information. Encoded as per RFC 5580.</p> <p>NOTE This attribute is expected from the AAA server in the initial request location delivery method as mentioned in RFC 5580.</p>

Hotspot (WISPr) Accounting Request [Start]

The table lists the attribute details of messages sent by the controller to the Hotspot (WISPr) module.

TABLE 21 Hotspot (WISPr) accounting request (start) attributes

Attribute	Attribute ID	Presence	Type	Description
User-Name	1	M	String	This attribute is the logon user name.
NAS-IP-Address	4	C	IP Address	This attribute is the IP address of the AP which is serving the station or controller's control IP address, controller's management IP address and user defined value.
NAS-Port	5	O	Integer	This attribute is the AID value.
Framed-IP-Address	8	O	IP Address	This attribute is STA's IP address.
Class	25	O	Integer	This attribute is sent by the server in access accept and the client should include this attribute in the accounting request without modification.
Vendor-Specific	26	O	Integer	Vendor ID: WISPr: 14122 Vendor Type: 1 VSA: WISPr-Location-ID

TABLE 21 Hotspot (WISPr) accounting request (start) attributes (continued)

Attribute	Attribute ID	Presence	Type	Description
				VSA Length: Variable This attribute is a configurable value in the hotspot (WISPr) user interface.
Vendor-Specific	26	O	Integer	Vendor ID: WISPr: 14122 Vendor Type: 2 VSA: WISPr-Location-Name VSA Length: Variable This attribute is a configurable value in the hotspot (WISPr) user interface.
Vendor-Specific	26	O	Integer	Vendor ID: Ruckus: 25053 Vendor Type: 2 VSA: Ruckus-STA-RSSI (2) VSA Length: Variable This attribute can only be present with Acct-Status-Type = Interim or Stop.
Vendor-Specific	26	O	String	Vendor ID: Ruckus: 25053 Vendor Type: 3 VSA: Ruckus-SSID (3) VSA Length: Variable Reports the associated WLANs SSID in the access request and accounting packet, Ruckus VSA is received only from Ruckus AP.
Vendor-Specific	26	O	String	Vendor ID: Ruckus: 25053 Vendor Type: 5 VSA: Ruckus-Location VSA Length: Variable Reports the device location for this AP. This is a configurable value in the device location setting. Ruckus VSA is received only from Ruckus AP. It is optional for 3rd party APs.
Vendor-Specific	26	O	Integer	Vendor ID: Ruckus: 25053 Vendor Type: 7 VSA: Ruckus-SCG-CBLADE-IP VSA VSA Length: Variable This attribute indicate the control plane IP address that is being used.
Vendor-Specific	26	O	Integer	Vendor ID: Ruckus: 25053

TABLE 21 Hotspot (WISPr) accounting request (start) attributes (continued)

Attribute	Attribute ID	Presence	Type	Description
				Vendor Type: 8 VSA: Ruckus-SCG-DBLADE-IP VSA VSA Length: Variable This attribute value is observed by NBI, when the GRE tunnel is set up.
Called Station ID	30	M	String	This attribute allows NAS to send the ID (BSSID), which is called by the user. It is MAC of the AP. It supports 2 types of values, namely BSSID:SSID, where BSSID is the MAC address of the WLAN on AP. The second value is AP-MAC:SSID, where AP-MAC is the MAC address of the AP. The letters in the MAC address are in uppercase. For example: 11-22-33-AA-BB-CC:SSID
Calling Station ID	31	M	String	STA's MAC address the letters in the MAC address are in uppercase. For example, 11-22-33-AA-BB-CC.
NAS-Identifier	32	C	Integer	This attribute contains a string identifying the NAS originating the access request. It supports 3 types of values for BSSID (MAC address of the WLAN on AP). AP-MAC (MAC address of AP) is a user defined attribute where the maximum length is 62. This attribute can also be configured as per the configuration specified on the WLAN configuration page of the controller web interface.
Proxy-State	33	O	Octets	This attribute is available to be sent by a proxy server (controller) to another server (AAA server) when forwarding an access request, accounting request (start, stop or interim) and <u>must</u> be returned unmodified in the access accept, access reject, access challenge and accounting response.
Acct-Status-Type	40	M	Integer	This attribute has the following values where 1 is Start, 2 is Stop, 3 is Interim, 7 are On and 8 are Off.
Acct-Delay-Time	41	C	Integer	This attribute can only be seen in accounting retry packets. This is a configurable option and by default this attribute is disabled.
Acct-Session-ID	44	M	Integer	This attribute is a unique accounting identity to facilitate easy matching of start, interim and stop records in a log file. The start,

TABLE 21 Hotspot (WISPr) accounting request (start) attributes (continued)

Attribute	Attribute ID	Presence	Type	Description
				interim and stop records for a given session must have the same <i>Acct-Session-ID</i> .
Acct-Authentic	45	M	Integer	This attribute value in EAP 802.1X-Auth and hotspot (WISPr) is: 1 for RADIUS-Auth and 2 for MAC-Auth local.
Acct-Terminate-Cause	49	M	Integer	This attribute can only be present with <i>Acct-Status-Type = Stop</i> .
Acct-Multi-Session-ID	50	O	Integer	This attribute is hand-off between APs, which triggers new accounting session (stop followed by start) with different session identifiers. Acct-Multi-Session-ID retains the same ID to tie multiple sessions.
Acct-Link-Count	51	O	Integer	Count of links in a multi-link session, when an accounting record is generated.
Event-Timestamp	55	O	Integer	This attribute is included in the Accounting-Request packet to record the time that this event occurred on NAS. For example, in seconds since January 1, 2013 00:00 UTC.
NAS-Port-Type	61	O	Integer	This attribute indicates the physical port type of the NAS, which authenticates the user.
Connect-Info	77	O	String	This attribute is sent from the NAS to indicate the nature of the user's connection.
Location-Information	127	C	Octets	This is a composite attribute, which provides meta data about the location information. It is encoded as per RFC 5580.
Location-Data	128	C	Octets	This attribute contains the actual location information. It is encoded as per RFC 5580. NOTE This attribute is included only if the location delivery method is the accounting request as specified in RFC 5580.
Basic-Location-Policy-Rules	129	M	String	This attribute provides the basic privacy policy associated to the location information. It is encoded as per RFC 5580.

TABLE 21 Hotspot (WISPr) accounting request (start) attributes (continued)

Attribute	Attribute ID	Presence	Type	Description
				<p>NOTE This attribute is included only if the location delivery method is the accounting request as specified in RFC 5580.</p>
Extended-Location-Policy-Rules	130	M	String	<p>This attribute provides the extended privacy policy for the target whose location is specified. This attribute is sent with the above attribute (<i>basic location policy</i>). It is encoded as per RFC 5580.</p> <p>NOTE This attribute is included only if the location delivery method is the accounting request as specified in RFC 5580.</p>

Hotspot (WISPr) Accounting Request [Stop/Interim]

The table lists the attribute details of messages sent by the controller to the Hotspot (WISPr) module.

TABLE 22 Hotspot (WISPr) accounting request (stop/interim) attributes

Attribute	Attribute ID	Presence	Type	Description
User-Name	1	M	String	This attribute is the logon user name.
NAS-IP-Address	4	C	IP Address	This attribute is the IP address of the AP which is serving the station or controller's control IP address, controller's management IP address and user defined value.
NAS-Port	5	O	Integer	This attribute is the AID value.
Framed-IP-Address	8	O	IP Address	This attribute is STA's IP address.
Class	25	O	Integer	This attribute is sent by the server in access accept and the client should include this attribute in the accounting request without modification.
Vendor-Specific	26	O	Integer	Vendor ID: WISPr: 14122 Vendor Type: 1 VSA: WISPr-Location-ID VSA Length: Variable

TABLE 22 Hotspot (WISPr) accounting request (stop/interim) attributes (continued)

Attribute	Attribute ID	Presence	Type	Description
				This attribute is a configurable value in the hotspot (WISPr) user interface.
Vendor-Specific	26	O	Integer	Vendor ID: WISPr: 14122 Vendor Type: 2 VSA: WISPr-Location-Name VSA Length: Variable This attribute is a configurable value in the hotspot (WISPr) user interface.
Vendor-Specific	26	O	Integer	Vendor ID: Ruckus: 25053 Vendor Type: 2 VSA: Ruckus-STA-RSSI (2) VSA Length: Variable This attribute can only be present with Acct-Status-Type = Interim or Stop.
Vendor-Specific	26	O	String	Vendor ID: Ruckus: 25053 Vendor Type: 3 VSA: Ruckus-SSID (3) VSA Length: Variable Reports the associated WLANs SSID in the access request and accounting packet, Ruckus VSA is received only from Ruckus AP.
Vendor-Specific	26	O	String	Vendor ID: Ruckus: 25053 Vendor Type: 5 VSA: Ruckus-Location VSA Length: Variable Reports the device location for this AP. This is a configurable value in the device location setting. Ruckus VSA is received only from Ruckus AP. It is optional for 3rd party APs.
Vendor-Specific	26	O	Integer	Vendor ID: Ruckus: 25053 Vendor Type: 7 VSA: Ruckus-SCG-CBLADE-IP VSA VSA Length: Variable This attribute indicate the control plane IP address that is being used.
Vendor-Specific	26	O	Integer	Vendor ID: Ruckus: 25053

TABLE 22 Hotspot (WISPr) accounting request (stop/interim) attributes (continued)

Attribute	Attribute ID	Presence	Type	Description
				Vendor Type: 8 VSA: Ruckus-SCG-DBLADE-IP VSA VSA Length: Variable This attribute value is observed by NBI, when the GRE tunnel is set up.
Called Station ID	30	M	String	This attribute allows NAS to send the ID (BSSID), which is called by the user. It is MAC of the AP. It supports 2 types of values, namely BSSID:SSID, where BSSID is the MAC address of the WLAN on AP. The second value is AP-MAC:SSID, where AP-MAC is the MAC address of the AP. The letters in the MAC address are in uppercase. For example: 11-22-33-AA-BB-CC:SSID
Calling Station ID	31	M	Integer	STA's MAC address the letters in the MAC address are in uppercase. For example, 11-22-33-AA-BB-CC.
NAS-Identifier	32	C	Integer	This attribute contains a string identifying the NAS originating the access request. It supports 3 types of values for BSSID (MAC address of the WLAN on AP). AP-MAC (MAC address of AP) is a user defined attribute where the maximum length is 62. This attribute can also be configured as per the configuration specified on the WLAN configuration page of the controller web interface.
Proxy-State	33	O	Octets	This attribute is available to be sent by a proxy server (controller) to another server (AAA server) when forwarding an access request, accounting request (start, stop or interim) and <u>must</u> be returned unmodified in the access accept, access reject, access challenge and accounting response.
Acct-Status-Type	40	M	Integer	This attribute has the following values where 1 is Start, 2 is Stop, 3 is Interim, 7 are On and 8 are Off.
Acct-Delay-Time	41	C	Integer	This attribute can only be seen in accounting retry packets. This is a configurable option

TABLE 22 Hotspot (WISPr) accounting request (stop/interim) attributes (continued)

Attribute	Attribute ID	Presence	Type	Description
				and by default this attribute is disabled.
Acct-Input-Octets	42	M	Integer	This attribute indicates the number of octets received from the port over the course of this service provided.
Acct-Output-Octets	43	M	Integer	This attribute indicates the number of octets sent to the port in the course of delivering this service.
Acct-Session-ID	44	M	Integer	This attribute is a unique accounting identity to facilitate easy matching of start, interim and stop records in a log file. The start, interim and stop records for a given session must have the same <i>Acct-Session-ID</i> .
Acct-Authentic	45	M	Integer	This attribute value in EAP 802.1X-Auth and hotspot (WISPr) is: 1 for RADIUS-Auth and 2 for MAC-Auth local.
Acct-Session-Time	46	M	Integer	This attribute can only be present with <i>Acct-Status-Type = Interim, Stop</i> .
Acct-Terminate-Cause	49	M	Integer	This attribute can only be present with <i>Acct-Status-Type = Stop</i> .
Acct-Multi-Session-ID	50	O	Integer	This attribute is hand-off between APs, which triggers new accounting session (stop followed by start) with different session identifiers. Acct-Multi-Session-ID retains the same ID to tie multiple sessions.
Acct-Link-Count	51	O	Integer	Count of links in a multi-link session, when an accounting record is generated.
Acct-Input-Gigawords	52	M	Integer	This attribute can only be present with <i>Acct-Status-Type = Interim, Stop</i> .
Acct-Output-Gigawords	53	M	Integer	This attribute can only be present with <i>Acct-Status-Type = Interim, Stop</i> .
Event-Timestamp	55	O	Integer	This attribute is included in the Accounting-Request packet to record the time that this event occurred on NAS. For example, in seconds since January 1, 2013 00:00 UTC.
NAS-Port-Type	61	O	Integer	This attribute indicates the physical port type of the NAS, which authenticates the user.

TABLE 22 Hotspot (WISPr) accounting request (stop/interim) attributes (continued)

Attribute	Attribute ID	Presence	Type	Description
Connect-Info	77	O	Integer	This attribute is sent from the NAS to indicate the nature of the user's connection.
Location-Information	127	M	String	This is a composite attribute, which provides meta data about the location information. It is encoded as per RFC 5580. NOTE This attribute is included only if the location delivery method is accounting request as specified in RFC 5580.
Location-Data	128	C	Octets	This attribute contains the actual location information. It is encoded as per RFC 5580. NOTE This attribute is included only if the location delivery method is accounting request as specified in RFC 5580.
Basic-Location-Policy-Rules	129	M	String	This attribute provides the basic privacy policy associated to the location information. It is encoded as per RFC 5580. NOTE This attribute is included only if the location delivery method is accounting request as specified in RFC 5580.
Extended-Location-Policy-Rules	130	C	Octets	This attribute provides the extended privacy policy for the target whose location is specified. This attribute is sent with the above attribute (<i>basic location policy</i>). It is encoded as per RFC 5580.

TABLE 22 Hotspot (WISPr) accounting request (stop/interim) attributes (continued)

Attribute	Attribute ID	Presence	Type	Description
				<p>NOTE This attribute is included only if the location delivery method is accounting request as specified in RFC 5580.</p>

Hotspot (WISPr) Accounting Response

The table lists the attribute details of messages received by the controller to the Hotspot (WISPr) module.

TABLE 23 Hotspot (WISPr) accounting response attributes

Attribute	Presence	Type	Description
Response Authenticator	M	Integer	MD5(Code ID Length RequestAuth RequestAuth RequestAuth Attributes Secret)

Hotspot 2.0 Authentication

- [Hotspot 2.0 Authentication Overview](#).....73
- [SIM Based Authentication - Access Request](#).....73
- [R2 Device Authentication](#).....74
- [Hotspot 2.0 VSAs](#).....77

Hotspot 2.0 Authentication Overview

Hotspot 2.0 WLAN supports 802.1x authentication and passpoint technology. Passpoint enabled devices (R2 devices) connect to the network automatically based on their PPS-MO and facilitates seamless roaming for users on Wi-Fi network.

WLAN supports Hotspot 2.0 passpoint enabled devices, which connect to the network and are provisioned with PPS-MO. R2 users can onboard PPS-MO through authentication procedure using RADIUS credentials. Non SIM based authentication (EAP-TTLS) is supported as per the WFA RFC mandate for Hotspot 2.0 R2 devices. SIM based authentication (EAP SIM and EAP AKA) is supported as per the WFA RFC mandate for Hotspot 2.0 R1 devices.

SIM based authentication is similar to [EAP - Full Authentication – 3GPP Solution](#) on page 31 except that RADIUS message include Hotspot 2.0 specific attributes. SIM based authentication is also applicable for R1 devices associated with Hotspot 2.0 WLAN and RADIUS messages are proxied to the external AAA server.

R2 devices are associated with Hotspot 2.0 WLAN on receiving the PPS-MO from the controller.

NOTE

For this release, TTLS RADIUS authentication is supported. There is no support for EAP-SIM.

SIM Based Authentication - Access Request

SIM based authentication for Hotspot 2.0 devices is similar to [EAP - Full Authentication – 3GPP Solution](#). In addition to the parameters mentioned in each of the following RADIUS access-accept. The table lists the attributes specific to Hotspot 2.0.

- [RADIUS Access Request \[ID\]](#) on page 32
- [RADIUS Access Request \[EAP Response \(NONCE_MT\)\]](#) on page 36
- [RADIUS Access Request \[EAP Response \(SRES\)\]](#) on page 43

TABLE 24 Hotspot 2.0 RADIUS access request attributes

Attribute	Attribute ID	Presence	Type	Description
Vendor-Specific	26	C	String	Vendor ID: 40808 Vendor Type: 2 VSA: AP Version VSA Length: Variable This attribute indicates version 0 as R1 compliant AP and version 1 as R2 compliant AP.
Vendor-Specific	26	C	String	Vendor ID: 40808

TABLE 24 Hotspot 2.0 RADIUS access request attributes (continued)

Attribute	Attribute ID	Presence	Type	Description
				Vendor Type: 3 VSA: Mobile Device Version VSA Length: Variable This attribute indicates version 0 as R1 compliant AP and version 1 as R2 compliant AP. Version 1 also includes the update identifier details.

R2 Device Authentication

In the R2 device authentication where PPS-MO is provisioned by an external OSU, RADIUS access request is always proxied to the remote AAA server when the device connects to the Hotspot 2.0 WLAN. RAC proxies the request to the AAA server based on the realm configuration defined in **Services&Profiles > Hotspot 2.0** of the controller web interface.

The figure shows the call flow for R2 devices when PPS-MO is received from external OSU. RAC does not decode the EAP payload and certificate details. It merely proxy's the request based on the RADIUS username attribute used in the request.

FIGURE 4 R2 device authentication

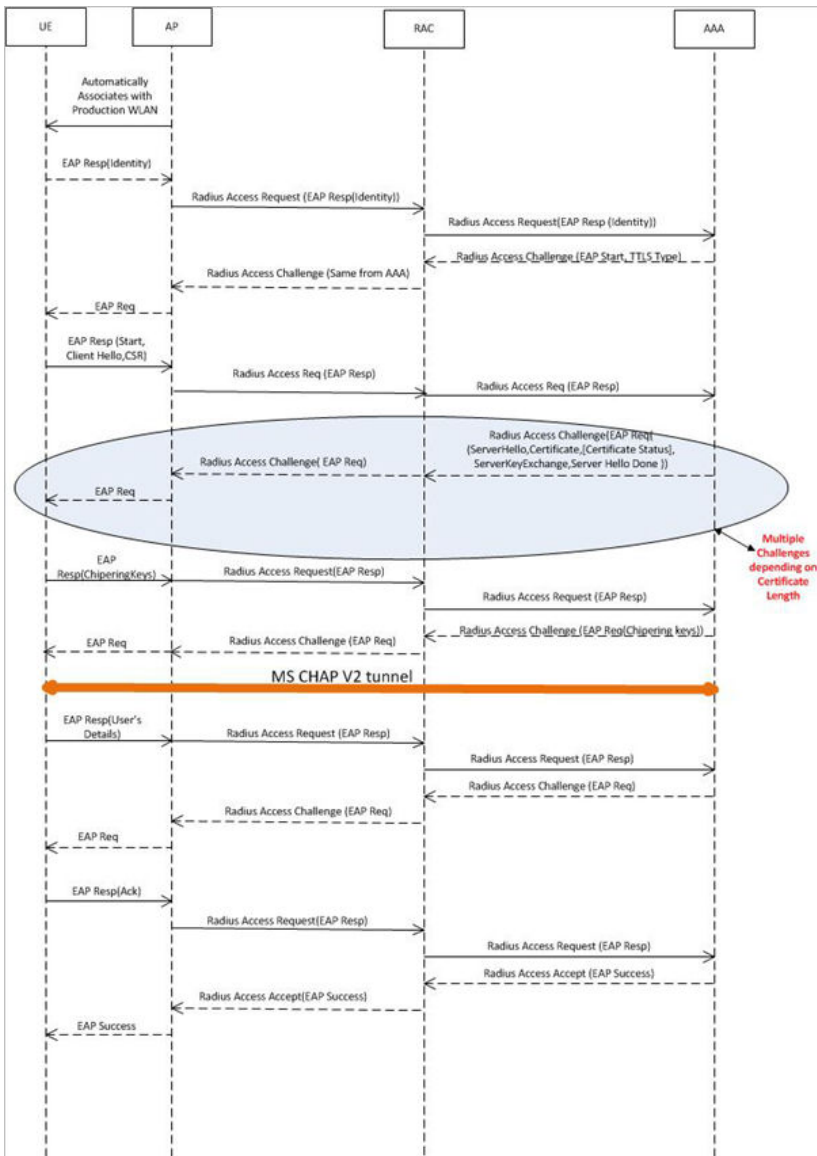

Access Request

The table lists the attributes specific to Hotspot 2.0.

TABLE 25 Hotspot 2.0 RADIUS access request attributes

Attribute	Attribute ID	Presence	Type	Description
Vendor-Specific	26	C	String	Vendor ID: 40808 Vendor Type: 2 VSA: AP Version VSA Length: Variable This attribute indicates version 0 as R1 compliant

TABLE 25 Hotspot 2.0 RADIUS access request attributes (continued)

Attribute	Attribute ID	Presence	Type	Description
Vendor-Specific	26	C	String	<p>AP and version 1 as R2 compliant AP.</p> <p>Vendor ID: 40808</p> <p>Vendor Type: 3</p> <p>VSA: Mobile Device Version</p> <p>VSA Length: Variable</p> <p>This attribute indicates version 0 as R1 compliant AP and version 1 as R2 compliant AP. Version 1 also includes the update identifier details.</p>

Access Response

The table lists the attributes specific to Hotspot 2.0.

TABLE 26 Hotspot 2.0 RADIUS access response attributes

Attribute	Attribute ID	Presence	Type	Description
Vendor-Specific	26	C	String	<p>Vendor ID: 40808</p> <p>Vendor Type: 1</p> <p>VSA: Subscription Remediation Needed</p> <p>VSA Length: Variable</p> <p>This attribute provides the remediation URL.</p>
Vendor-Specific	26	C	String	<p>Vendor ID: 40808</p> <p>Vendor Type: 4</p> <p>VSA: De-authentication Request</p> <p>VSA Length: Variable</p> <p>This attribute is applicable only for R2 devices. It gives the de-authenticated URL and the reauthentication delay.</p>
Vendor-Specific	26	C	String	<p>Vendor ID: 40808</p> <p>Vendor Type: 5</p> <p>VSA: Session Information URL</p> <p>VSA Length: Variable</p> <p>This attribute provides the URL details seen before session termination.</p>

NOTE

Attributes such as Client Hello, Server Hello are standard TLS 1.0 specific attributes and are embedded within EAP. For details refer to RFC 2246.

Hotspot 2.0 VSAs

There are vendor specific attributes for Hotspot 2.0 as mandated by WFA Hotspot 2.0 specifications along with the regular RADIUS message attributes (as per RFC 2865).

The figure indicates the VSA fields in a Hotspot 2.0 subscription remediation flow.

FIGURE 5 Hotspot 2.0 VSA fields

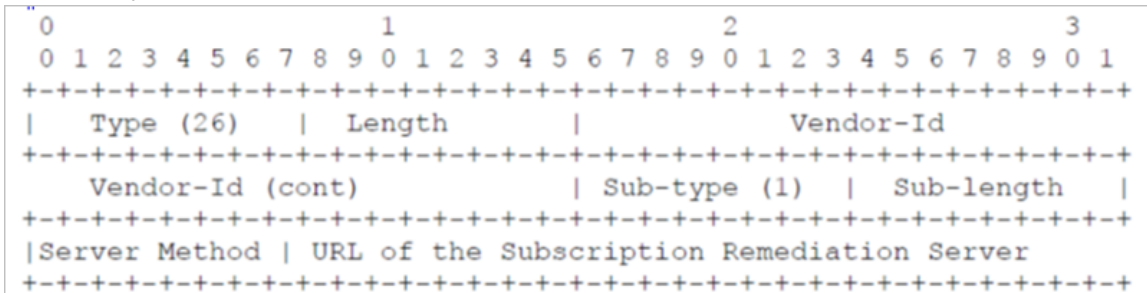

Accounting - Controller Initiated Accounting Messages

- Accounting - Controller Initiated Accounting Messages (TTG Sessions)..... 79
- RADIUS Accounting Request [Start]..... 80
- RADIUS Accounting Request [Stop/Interim Update]..... 89
- RADIUS Accounting Response.....94
- AP Initiated Accounting Messages (PDG/LBO Sessions)..... 95

Accounting - Controller Initiated Accounting Messages (TTG Sessions)

In this call flow, the controller initiates RADIUS accounting messages towards accounting AAA server after EAP-SIM authentication and when the data session is established. The figure shows the detailed call flow.

NOTE

The Accounting Interface between SZ or vSZ and the AAA server is IPv4 as well as IPv6. If SCG is configured with an IPv6 address and AAA is also configured with an IPv6 address and reachable from SZ/vSZ, then Accounting messages with IPv6 can be exchanged. This includes Account-Start/Interim/Stop/On/Off. For details on how to configure IPv6 Accounting AAA, refer the SCG vSZ-H Administrator guide.

FIGURE 6 RADIUS Accounting call flow

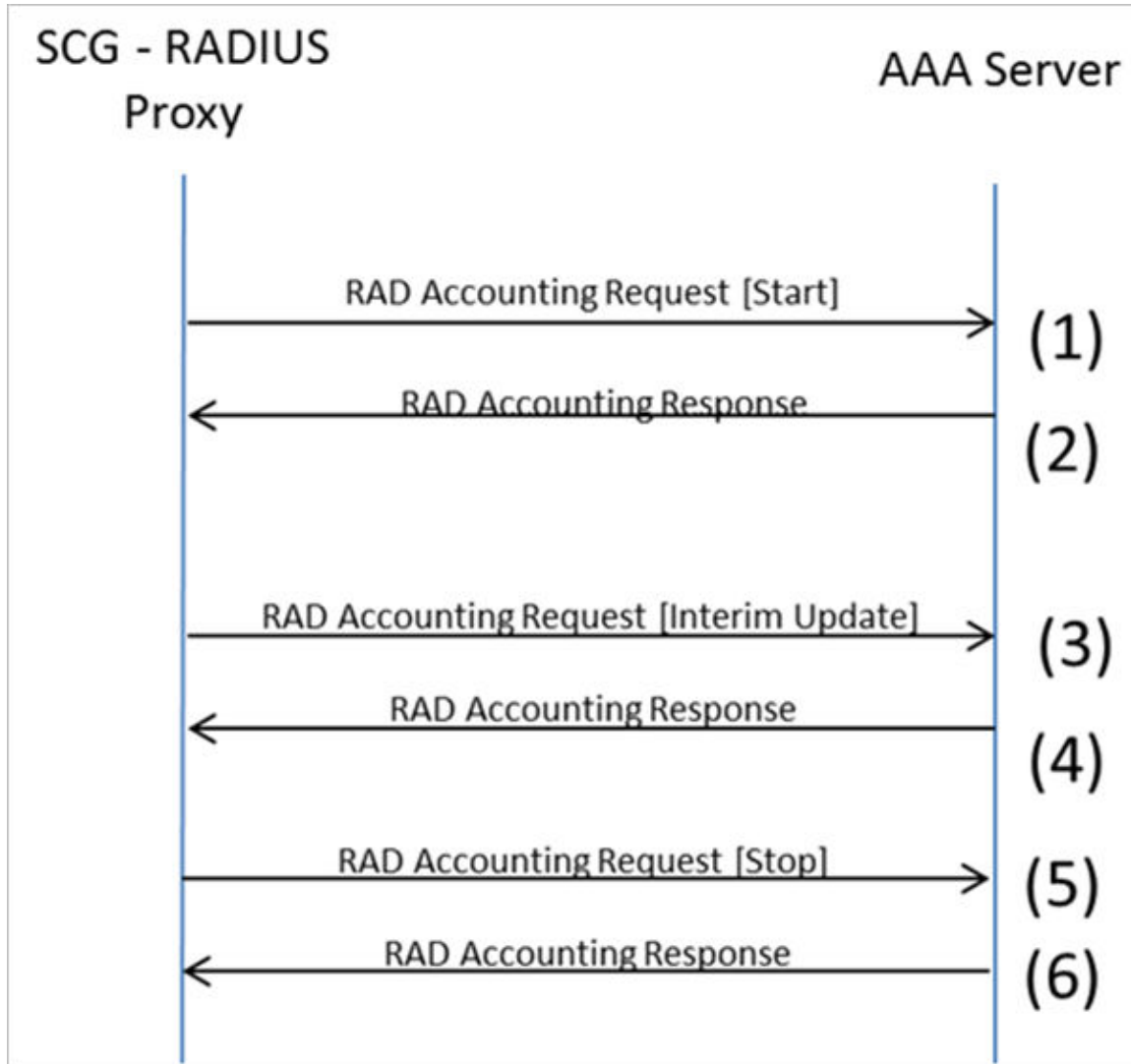

This section covers:

- [RADIUS Accounting Request \[Start\]](#) on page 80
- [RADIUS Accounting Request \[Stop/Interim Update\]](#) on page 89
- [RADIUS Accounting Response](#) on page 94

RADIUS Accounting Request [Start]

The table lists the attribute details of messages sent by the controller to the AAA server.

TABLE 27 RADIUS accounting attributes

Attribute	Attribute ID	Presence	Type	Description
User-Name	1	M	String	The username of the given accounting session.

TABLE 27 RADIUS accounting attributes (continued)

Attribute	Attribute ID	Presence	Type	Description
NAS-IP-Address	4	C	Integer	This attribute is the IP address of the AP which is serving the station or controller's control IP address, controller's management IP address and user defined value.
Service-Type	6	O	Integer	Indicates the type of service based on the user request or the type of service to be provided.
Framed-IP-Address	8	O	IP Address	This attribute indicates the address to be configured for the user.
Login-IP-Host	14	M	Integer	Variable IP address.
Class	25	O	Integer	This attribute is sent by the server in access accept. The client should include this attribute in the accounting request without modifying it.
Vendor-Specific	26	C	Integer	Vendor ID:Ruckus:25053 VSA: Ruckus-APN-NI (104) VSA Length: Variable This attribute carries the APN subscribed by the user. It contains only the network identifier (NI), which is part of the APN. The operator identifier part is stored separately in Ruckus-APN-OI.
Vendor-Specific	26	C	Integer	Vendor ID:Ruckus:25053 VSA: Ruckus-APN-OI (111) VSA Length: Variable It contains the <i>Operator ID</i> , which is part of the APN name.
Vendor-Specific	26	C	String	Vendor ID: Ruckus:25053 VSA: Ruckus-IMSI (102) VSA Length: Variable This Ruckus VSA contains values to be used by the controller's CDR generating module.
Vendor-Specific	26	C	Integer	Vendor ID: Ruckus:25053 VSA: Ruckus-NAS-Type (109) VSA Length: 6

Accounting - Controller Initiated Accounting Messages
RADIUS Accounting Request [Start]

TABLE 27 RADIUS accounting attributes (continued)

Attribute	Attribute ID	Presence	Type	Description
				This Ruckus VSA contains the value to be used by the controller's CDR generating module.
Vendor-Specific	26	M	Integer	Vendor ID: 3GPP: 10415 VSA: 3GPP-RAT-Type (21) VSA Length: 3 This Ruckus VSA contains the value to be used by controller's CDR generating module.
Vendor-Specific	26	O	String	Vendor ID: 3GPP: 10415 VSA: 3GPP-GPRS-Negotiated-QoS-Profile (5) VSA Length: Variable QoS bytes (octets). This attribute contains QoS received from AAA or negotiated by GGSN, if it is not received from the core network, The controller will use the default QoS. GPP-GPRS-Negotiated-QoS-Profile will be present in this message.
Vendor-Specific	26	C	Integer	Vendor ID: Ruckus:25053 VSA: Ruckus-Charging-Charac (118) VSA Length: Variable This attribute carries the charging characteristics value, which is received from the AAA server. This attribute carries the charging characteristics value, which is received from the AAA server.
Vendor-Specific	26	C	Integer	Vendor ID: Ruckus:25053 VSA: Ruckus-PDP-Type (119) VSA Length: 4 This Ruckus VSA contains the value to be used by the controller's CDR generating module.
Vendor-Specific	26	C	Integer	Vendor ID: Ruckus:25053 VSA: Ruckus-ChCh-Selection-Mode (121) VSA Length: 3

TABLE 27 RADIUS accounting attributes (continued)

Attribute	Attribute ID	Presence	Type	Description
				This Ruckus VSA contains the value to be used by the controller's CDR generating module.
Vendor-Specific	26	C	Integer	Vendor ID: 25053 VSA: Ruckus-AAA-IP (122) VSA Length: 6 This Ruckus VSA contains the value to be used by the controller's CDR generating module.
Vendor-Specific	26	C	Integer	Vendor ID: Ruckus:25053 VSA: Ruckus-SCG-CBLADE-IP (7) VSA Length: 6 Reports the control plane IP address. Ruckus VSAs are received from Ruckus APs only. It is optional for 3rd party APs.
Vendor-Specific	26	C	Integer	Vendor ID: Ruckus:25053 VSA: Ruckus-SCG-DBLADE-IP (8) VSA Length: 6 Reports the data plane IP address. Ruckus VSAs are received from Ruckus APs only. It is optional for 3rd party APs.
Vendor-Specific	26	C	Integer	Vendor ID: Ruckus:25053 VSA: Ruckus-Dynamic-Address-Flag (120) VSA Length: 3 The flag value of this Ruckus VSA is either 0 or 1. This attribute contains the value to be used by the controller's CDR generating module.
Vendor-Specific	26	M	Integer	Vendor ID: 25053 VSA: Ruckus-SGSN-IP (117) VSA Length: 4 This Ruckus VSA contains the value to be used by the controller's CDR generating module.

Accounting - Controller Initiated Accounting Messages
RADIUS Accounting Request [Start]

TABLE 27 RADIUS accounting attributes (continued)

Attribute	Attribute ID	Presence	Type	Description
Called Station ID	30	O	Integer	This attribute supports two kinds of formats, namely, BSSID:SSID, which is the MAC address of the WLAN on AP and AP-MAC:SSID which is the MAC address of AP. The letters in the MAC address are in uppercase. For example: 11-22-33-AA-BB-CC:SSID.
Calling Station ID	31	M	String	Allows NAS to send the ID (UE MAC), which indicates as to who is calling this server.
NAS-Identifier	32	C	Integer	NAS-IP-Address or NAS-Identifier attribute is mandatory in received messages. It supports 3 types of values, namely BSSID (MAC address of the WLAN on AP), AP-MAC (MAC address of AP) and user defined address (maximum length of 62).
Proxy-State	33	C	Octets	This attribute is available to be sent by a proxy server (controller) to another server (AAA server) when forwarding an access request, accounting request (start, stop or interim) and <u>must</u> be returned unmodified in the access accept, access reject, access challenge and accounting response.
Acct-Status-Type	40	M	Integer	This attribute indicates whether the <i>Accounting-Request</i> attribute marks the beginning of the user service (Start) with the value of 1 as (Start).
Acct-Delay-Time	41	C	Integer	In case the accounting message gets retransmitted this attribute will contain the time stamp of the consecutive retransmitted message.
Acct-Session-ID	44	M	Integer	This attribute is a unique accounting identity to facilitate easy matching of start, interim and stop records in a log file. The start, interim and stop records for a given session must have the same <i>Acct-Session-ID</i> .

TABLE 27 RADIUS accounting attributes (continued)

Attribute	Attribute ID	Presence	Type	Description
Event-Timestamp	55	O	Integer	This attribute is included in the Accounting-Request packet to record the time that this event occurred on NAS. For example, in seconds since January 1, 2013 00:00 UTC.
NAS-Port-Type	61	O	Integer	Indicates the physical port type of NAS, which authenticates the user.
Chargeable User ID	89	C	String	This attribute is MSISDN or any chargeable user identity returned by the AAA server. This attribute is unchanged when it is received in the RADIUS Access Accept message.
Location-Information	127	M	Octets	Note: This attribute is included only when the expected location delivery method is accounting request as specified in RFC 5580.
Location-Data	128	C	Octets	This attribute contains the actual location information. It is encoded as per RFC 5580. Note: This attribute is included only when the expected location delivery method is accounting request as specified in RFC 5580.
Basic-Location-Policy-Rules	129	M	String	This attribute provides the basic privacy policy associated to the location information. It is encoded as per RFC 5580. Note: This attribute is included only when the expected location delivery method is accounting request as specified in RFC 5580.
Extended-Location-Policy-Rules	130	C	Octets	This attribute provides the extended privacy policy for the target whose location is specified. This attribute is sent with the above attribute (<i>basic location policy</i>). It is encoded as per RFC 5580. Note: This attribute is included only when the expected location delivery method is accounting

Accounting - Controller Initiated Accounting Messages
RADIUS Accounting Request [Start]

TABLE 27 RADIUS accounting attributes (continued)

Attribute	Attribute ID	Presence	Type	Description
				request as specified in RFC 5580.

TABLE 28 RADIUS accounting attributes

Attribute	Attribute ID	Presence	Type	Description
User-Name	1	M	String	The username of the given accounting session.
NAS-IP-Address	4	C	Integer	This attribute is the IP address of the AP which is serving the station/UE.
Service-Type	6	O	Integer	Indicates the type of service based on the user request or the type of service to be provided.
Framed-IP-Address	8	O	IP Address	This attribute indicates the address to be configured for the user.
Login-IP-Host	14	M	Integer	Variable IP address.
Class	25	O	Integer	This attribute is sent by the server in access accept. The client should include this attribute in the accounting request without modifying it.
Vendor-Specific	26	C	Integer	Vendor ID:Ruckus:25053 VSA: Ruckus-APN-NI (104) VSA Length: Variable This attribute carries the APN subscribed by the user. It contains only the network identifier (NI), which is part of the APN. The operator identifier part is stored separately in Ruckus-APN-OI.
Vendor-Specific	26	C	Integer	Vendor ID:Ruckus:25053 VSA: Ruckus-APN-OI (111) VSA Length: Variable It contains the <i>Operator ID</i> , which is part of the APN name.
Vendor-Specific	26	C	String	Vendor ID: Ruckus:25053 VSA: Ruckus-IMSI (102) VSA Length: Variable This Ruckus VSA contains values to be used by the controller's CDR generating module.
Vendor-Specific	26	C	Integer	Vendor ID: Ruckus:25053 VSA: Ruckus-NAS-Type (109) VSA Length: 6 This Ruckus VSA contains the value to be used by the controller's CDR generating module.
Vendor-Specific	26	M	Integer	Vendor ID: 3GPP: 10415 VSA: 3GPP-RAT-Type (21) VSA Length: 3 This Ruckus VSA contains the value to be used by controller's CDR generating module.
Vendor-Specific	26	O	String	Vendor ID: 3GPP: 10415 VSA: 3GPP-GPRS-Negotiated-QoS-Profile (5)

TABLE 28 RADIUS accounting attributes (continued)

Attribute	Attribute ID	Presence	Type	Description
				VSA Length: Variable QoS bytes (octets). This attribute contains QoS received from AAA or negotiated by GGSN, if it is not received from the core network, The controller will use the default QoS. GPP-GPRS-Negotiated-QoS-Profile will be present in this message.
Vendor-Specific	26	C	Integer	Vendor ID: Ruckus:25053 VSA: Ruckus-Charging-Charac (118) VSA Length: Variable This attribute carries the charging characteristics value, which is received from the AAA server. This attribute carries the charging characteristics value, which is received from the AAA server.
Vendor-Specific	26	C	Integer	Vendor ID: Ruckus:25053 VSA: Ruckus-PDP-Type (119) VSA Length: 4 This Ruckus VSA contains the value to be used by the controller's CDR generating module.
Vendor-Specific	26	C	Integer	Vendor ID: Ruckus:25053 VSA: Ruckus-ChCh-Selection-Mode (121) VSA Length: 3 This Ruckus VSA contains the value to be used by the controller's CDR generating module.
Vendor-Specific	26	C	Integer	Vendor ID: 25053 VSA: Ruckus-AAA-IP (122) VSA Length: 6 This Ruckus VSA contains the value to be used by the controller's CDR generating module.
Vendor-Specific	26	C	Integer	Vendor ID: Ruckus:25053 VSA: Ruckus-SCG-CBLADE-IP (7) VSA Length: 6 Reports the control plane IP address. Ruckus VSAs are received from Ruckus APs only. It is optional for 3rd party APs.
Vendor-Specific	26	C	Integer	Vendor ID: Ruckus:25053 VSA: Ruckus-SCG-DBLADE-IP (8) VSA Length: 6 Reports the data plane IP address. Ruckus VSAs are received from Ruckus APs only. It is optional for 3rd party APs.
Vendor-Specific	26	C	Integer	Vendor ID: Ruckus:25053 VSA: Ruckus-Dynamic-Address-Flag (120) VSA Length: 3 The flag value of this Ruckus VSA is either 0 or 1. This attribute contains the value to be used by the controller's CDR generating module.

TABLE 28 RADIUS accounting attributes (continued)

Attribute	Attribute ID	Presence	Type	Description
Vendor-Specific	26	M	Integer	Vendor ID: 25053 VSA: Ruckus-SGSN-IP (117) VSA Length: 4 This Ruckus VSA contains the value to be used by the controller's CDR generating module.
Called Station ID	30	O	Integer	This attribute supports two kinds of formats, namely, BSSID:SSID, which is the MAC address of the WLAN on AP and AP-MAC:SSID which is the MAC address of AP. The letters in the MAC address are in uppercase. For example: 11-22-33-AA-BB-CC:SSID.
Calling Station ID	31	M	String	Allows NAS to send the ID (UE MAC), which indicates as to who is calling this server.
NAS-Identifier	32	C	Integer	NAS-IP-Address or NAS-Identifier attribute is mandatory in received messages. It supports 3 types of values, namely BSSID (MAC address of the WLAN on AP), AP-MAC (MAC address of AP) and user defined address (maximum length of 62).
Proxy-State	33	C	Octets	This attribute is available to be sent by a proxy server (controller) to another server (AAA server) when forwarding an access request, accounting request (start, stop or interim) and <u>must</u> be returned unmodified in the access accept, access reject, access challenge and accounting response.
Acct-Status-Type	40	M	Integer	This attribute indicates whether the <i>Accounting-Request</i> attribute marks the beginning of the user service (Start) with the value of 1 as (Start).
Acct-Delay-Time	41	C	Integer	In case the accounting message gets retransmitted this attribute will contain the time stamp of the consecutive retransmitted message.
Acct-Session-ID	44	M	Integer	This attribute is a unique accounting identity to facilitate easy matching of start, interim and stop records in a log file. The start, interim and stop records for a given session must have the same <i>Acct-Session-ID</i> .
Event-Timestamp	55	O	Integer	This attribute is included in the Accounting-Request packet to record the time that this event occurred on NAS. For example, in seconds since January 1, 2013 00:00 UTC.
NAS-Port-Type	61	O	Integer	Indicates the physical port type of NAS, which authenticates the user.
Chargeable User ID	89	C	String	This attribute is MSISDN or any chargeable user identity returned by the AAA server. This attribute is unchanged when it is received in the RADIUS Access Accept message.
Location-Information	127	M	Octets	Note: This attribute is included only when the expected location delivery method is accounting request as specified in RFC 5580.
Location-Data	128	C	Octets	This attribute contains the actual location information. It is encoded as per RFC 5580. Note: This attribute is included only when the expected location delivery method is accounting request as specified in RFC 5580.
Basic-Location-Policy-Rules	129	M	String	This attribute provides the basic privacy policy associated to the location information. It is encoded as per RFC 5580. Note: This attribute is included only when the expected location delivery method is accounting request as specified in RFC 5580.
Extended-Location-Policy-Rules	130	C	Octets	This attribute provides the extended privacy policy for the target whose location is specified. This attribute is sent with the above attribute (<i>basic location policy</i>). It is encoded as per RFC 5580.

TABLE 28 RADIUS accounting attributes (continued)

Attribute	Attribute ID	Presence	Type	Description
				Note: This attribute is included only when the expected location delivery method is accounting request as specified in RFC 5580.

RADIUS Accounting Request [Stop/Interim Update]

The table lists the attribute details of messages sent by the controller to the AAA server.

TABLE 29 RADIUS accounting request (stop/interim update) attributes

Attribute	Attribute ID	Presence	Type	Description
User-Name	1	M	String	The username of the given accounting session.
NAS-IP-Address	4	C	Integer	This attribute is the IP address of the AP which is serving the station or controller's control IP address, controller's management IP address and user defined value.
Service-Type	6	O	Integer	Indicates the type of service based on the user request or the type of service to be provided.
Framed-IP-Address	8	O	IP Address	This attribute indicates the address to be configured for the user.
Login-IP-Host	14	O	Integer	Variable IP address.
Vendor-Specific	26	C	Integer	Vendor ID: Ruckus:25053 VSA: Ruckus-APN-NI(104) VSA Length: Variable This attribute carries the APN subscribed by the user. It contains only the network identifier (NI), which is part of the APN. The operator identifier part is stored separately in Ruckus-APN-OI.
Vendor-Specific	26	C	Integer	Vendor ID: Ruckus:25053 VSA: Ruckus-Selection-Mode (106) VSA Length: 6 This Ruckus VSA contains the value to be used by the controller's CDR generating module.
Vendor-Specific	26	C	Octets	Vendor ID: Ruckus:25053 VSA: Ruckus-APN-OI (111)

Accounting - Controller Initiated Accounting Messages
RADIUS Accounting Request [Stop/Interim Update]

TABLE 29 RADIUS accounting request (stop/interim update) attributes (continued)

Attribute	Attribute ID	Presence	Type	Description
				VSA Length: Variable This Ruckus VSA contains the value to be used by the controller's CDR generating module.
Vendor-Specific	26	C	String	Vendor ID: Ruckus:25053 VSA: Ruckus-IMSI (102) VSA Length: Variable This Ruckus VSA contains the value to be used by the controller's CDR generating module.
Vendor-Specific	26	M	Integer	Vendor ID: 25053 VSA: Ruckus-SGSN-IP (117) VSA Length: 4 This Ruckus VSA contains the value to be used by the controller's CDR generating module.
Vendor-Specific	26	C	Integer	Vendor ID: Ruckus:25053 VSA: Ruckus-NAS-Type (109) VSA Length: 6 This Ruckus VSA contains the value to be used by the controller's CDR generating module.
Vendor-Specific	26	O	Integer	Vendor ID: 3GPP: 10415 VSA: 3GPP-RAT-Type (21) VSA Length: 3 This Ruckus VSA contains the value to be used by the controller's CDR generating module.
Vendor-Specific	26	O	String	Vendor ID: 3GPP: 10415 VSA: 3GPP-GPRS-Negotiated-QoS-Profile(5) VSA Length: Variable QoS bytes (octets). This attribute contains QoS received from AAA or negotiated by GGSN, if it is not received from the core network, The controller will use the default QoS. GPP-GPRS-Negotiated-QoS-

TABLE 29 RADIUS accounting request (stop/interim update) attributes (continued)

Attribute	Attribute ID	Presence	Type	Description
				Profile will be present in this message.
Vendor-Specific	26	C	Integer	Vendor ID: Ruckus:25053 VSA: Ruckus-SCG-CBLADE-IP (7) VSA Length: 6 Reports the control plane IP address. Ruckus VSAs are received from Ruckus APs only. It is optional for 3rd party APs.
Vendor-Specific	26	C	Integer	Vendor ID: Ruckus:25053 VSA: Ruckus-SCG-DBLADE-IP (8) VSA Length: 6 Reports the control plane IP address. Ruckus VSAs are received from Ruckus APs only. It is optional for 3rd party APs.
Called Station ID	30	O	String	This attribute allows NAS to send the ID (BSSID), which is called by the user. It is MAC of the AP. It supports 2 types of values, namely BSSID:SSID, where BSSID is the MAC address of the WLAN on AP. The second value is AP-MAC:SSID, where AP-MAC is the MAC address of the AP. The letters in the MAC address are in uppercase. For example: 11-22-33-AA-BB-CC:SSID.
Calling Station ID	31	M	String	This attribute allows NAS to send the ID (UE MAC), which indicates as to who is calling this server. The value supported is STA's MAC address, where the letters in the MAC address are in uppercase. For example: 11-22-33-AA-BB-CC.
NAS-Identifier	32	C	Integer	NAS-IP-Address or NAS-Identifier attribute is mandatory in received messages. It supports 3 types of values, namely BSSID (MAC address of the WLAN on AP), AP-MAC (MAC address of AP) and

Accounting - Controller Initiated Accounting Messages
RADIUS Accounting Request [Stop/Interim Update]

TABLE 29 RADIUS accounting request (stop/interim update) attributes (continued)

Attribute	Attribute ID	Presence	Type	Description
				user defined address (maximum length of 62).
Acct-Status-Type	40	M	Integer	This attribute indicates the <i>Accounting-Request</i> type. Possible values are Stop(2), interim update (3).
Acct-Delay-Time	41	C	Integer	In case the accounting message gets retransmitted, this attribute will contain the time stamp of the consecutive retransmitted message.
Acct-Input-Octets	42	M	Integer	This attribute indicates the number of octets received from the port over the course of this service provided.
Acct-Output-Octets	43	M	Integer	This attribute indicates the number of octets sent to the port in the course of delivering this service.
Acct-Session-ID	44	M	Integer	This attribute is a unique accounting identity to facilitate easy matching of start, interim and stop records in a log file. The start, interim and stop records for a given session must have the same <i>Acct-Session-ID</i> .
Acct-Session-Time	46	M	Integer	This attribute indicates the number of seconds the user receives the service for.
Acct-Input-Packets	47	M	Integer	This attribute indicates the number of packets received from the port over the course of this service provided.
Acct-Output-Packets	48	M	Integer	This attribute indicates the number of packets sent to the port in the course of delivering this service.
Acct-Terminate-Cause	49	M	Integer	This attribute indicates how the session was terminated. This attribute can only be present in accounting request records where the <i>Acct-Status-Type</i> is set to Stop.
Acct-Input-Gigawords	52	M	Integer	This attribute indicates the number of times that the acct-input-octets counter wraps around 2^{32} over the course of this provided service.

TABLE 29 RADIUS accounting request (stop/interim update) attributes (continued)

Attribute	Attribute ID	Presence	Type	Description
Acct-Output-Gigawords	53	M	Integer	This attribute indicates the number of times the acct-input-octets counter is wrapped around 2^{32} in the course of delivering this service.
Event-Timestamp	55	O	Integer	This attribute is included in the accounting-request packet for recording the time in seconds that the event occurred on NAS. For example, January 1, 2013 00:00 UTC.
NAS-Port-Type	61	O	Integer	Indicates the physical port type of NAS, which authenticates the user.
Chargeable User ID	89	C	String	This attribute is MSISDN or any chargeable user identity returned by the AAA server. This attribute is unchanged when it is received in the RADIUS Access Accept message.
Location-Information	127	M	Octets	This is a composite attribute, which provides meta data about the location information. It is encoded as per RFC 5580. NOTE This attribute is included only when the expected location delivery method is accounting request as specified in RFC 5580.
Location-Data	128	C	Octets	This attribute contains the actual location information. It is encoded as per RFC 5580. NOTE This attribute is included only when the expected location delivery method is accounting request as specified in RFC 5580.

TABLE 29 RADIUS accounting request (stop/interim update) attributes (continued)

Attribute	Attribute ID	Presence	Type	Description
Basic-Location-Policy-Rules	129	M	String	<p>This attribute provides the basic privacy policy associated to the location information. It is encoded as per RFC 5580.</p> <p>NOTE This attribute is included only when the expected location delivery method is accounting request as specified in RFC 5580.</p>
Extended-Location-Policy-Rules	130	C	Octets	<p>This attribute provides the extended privacy policy for the target whose location is specified. This attribute is sent with the above attribute (<i>basic location policy</i>). It is encoded as per RFC 5580.</p> <p>NOTE This attribute is included only when the expected location delivery method is Accounting Request as specified in RFC 5580.</p>

RADIUS Accounting Response

The table lists the attribute details of messages sent by the AAA to the controller.

TABLE 30 RADIUS accounting response attributes

Attribute	Presence	Type	Description
Response Authenticator	M	Integer	MD5(Code ID Length RequestAuth RequestAuth RequestAuth Attributes Secret)

AP Initiated Accounting Messages (PDG/LBO Sessions)

The controller honors RADIUS accounting messages received from AP, for both Ruckus AP and 3rd Party AP. For accounting messages from AP, controller generates W-AN-CDR/S-CDR/W-CDR as configured in the controller UI (non-proxy mode), or proxy accounting messages received from AP to configured external AAA server (proxy mode).

The figure shows the controller proxy accounting messages from NAS to external AAA server.

FIGURE 7 AP initiated accounting messages

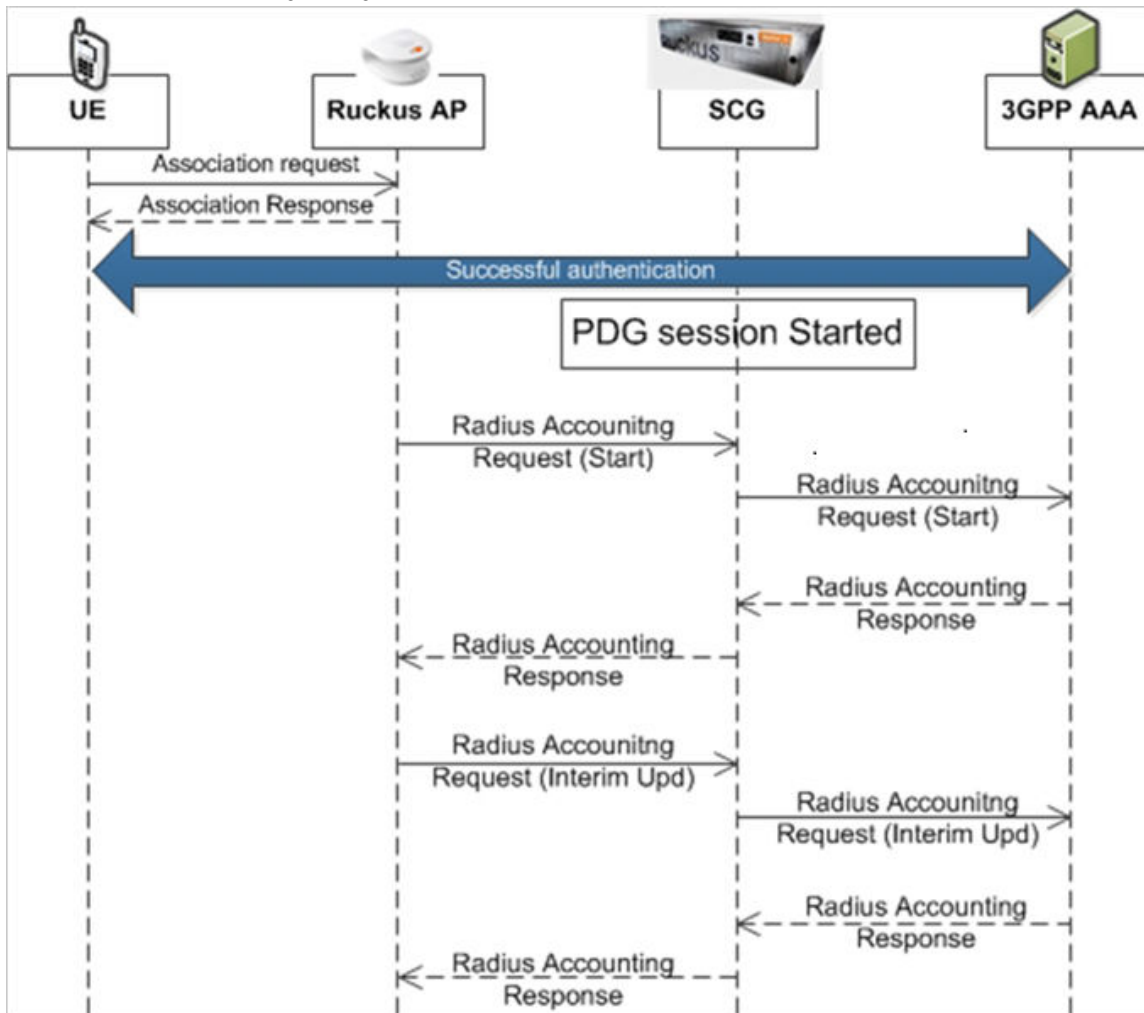

This section covers:

- [Accounting Start Messages](#) on page 96
- [Accounting Interim Update and Stop Messages](#) on page 100
- [Accounting On Messages](#) on page 105
- [Accounting Off Messages](#) on page 106

Accounting Start Messages

The table lists the attribute details of messages sent by the controller to the AAA server.

TABLE 31 Accounting start message attributes

Attribute	Attribute ID	Presence	Type	Description
User-Name	1	M	String	The username of the given accounting session.
NAS-IP-Address	4	C	Integer	This attribute is the IP address of the AP which is serving the station or controller's control IP address, controller's management IP address and user defined value.
NAS-Port	5	O	Integer	This attribute indicates the physical port number of the NAS which authenticates the user. The controller uses the association ID for the STA in the AP to represent this.
Framed-IP-Address	8	O	IP Address	This attribute indicates the address to be configured for the user.
Vendor-Specific	26	C	String	Vendor ID: Ruckus:25053 VSA: Ruckus-SSID (3) VSA Length: Variable Reports the associated WLANs SSID in access request and accounting packet. Ruckus VSAs are received from Ruckus APs only. It is optional for 3rd party APs.
Vendor-Specific	26	C	String	Vendor ID: Ruckus:25053 VSA: Ruckus-Location (5) VSA Length: Variable Reports the device location for this AP. This is a configurable value in the device location setting. Ruckus VSA is received only from Ruckus AP. It is optional for 3rd party APs.
Vendor-Specific	26	C	Integer	Vendor ID: Ruckus:25053 VSA: Ruckus-SCG-CBLADE-IP (7) VSA Length: 6 Reports the control plane IP address. Ruckus VSAs are received from Ruckus APs only. It is optional for 3rd party APs.

TABLE 31 Accounting start message attributes (continued)

Attribute	Attribute ID	Presence	Type	Description
Vendor-Specific	26	C	Integer	Vendor ID: Ruckus:25053 VSA: Ruckus-SCG-DBLADE-IP (8) VSA Length: 6 Reports the data plane IP address. Ruckus VSA is received only from Ruckus AP. It is optional for 3rd party APs.
Called Station ID	30	O	String	This attribute supports two kinds of formats, namely, BSSID:SSID, which is the MAC address of the WLAN on AP and AP-MAC:SSID which is the MAC address of AP. The letters in the MAC address are in uppercase. For example: 11-22-33-AA-BB-CC:SSID.
Calling Station ID	31	O	String	Allows NAS to send the ID (UE MAC), which indicates as to who is calling the STA's MAC address. The letters in the MAC address are in uppercase. For example: 11-22-33-AA-BB-CC.
NAS-Identifier	32	C	Integer	NAS-IP-Address or NAS-Identifier attribute is mandatory in received messages. It supports 3 types of values, namely BSSID (MAC address of the WLAN on AP), AP-MAC (MAC address of AP) and user defined address (maximum length of 62).
Proxy-State	33	C	Octets	This attribute is available to be sent by a proxy server (controller) to another server (AAA server) when forwarding an access request, accounting request (start, stop or interim) and <u>must</u> be returned unmodified in the access accept, access reject, access challenge and accounting response.
Acct-Status-Type	40	M	Integer	This attribute indicates whether the <i>Accounting-Request</i> attribute marks the beginning of the user service (Start). Start value is 1.

Accounting - Controller Initiated Accounting Messages
AP Initiated Accounting Messages (PDG/LBO Sessions)

TABLE 31 Accounting start message attributes (continued)

Attribute	Attribute ID	Presence	Type	Description
Acct-Delay-Time	41	C	Integer	This is a configurable option and by default this attribute is disabled. In case the accounting message gets retransmitted, this attribute contains the time stamp of the consecutive retransmitted message.
Acct-Session-ID	44	M	Integer	This attribute is a unique accounting identity to facilitate easy matching of start, interim and stop records in a log file. The start, interim and stop records for a given session must have the same <i>Acct-Session-ID</i> .
Acct-Authentic	45	M	Integer	This attribute indicates whether the user was authenticated through RADIUS server or NAS or remote authentication protocol.
Acct-Multi-Session-ID	50	O	Integer	This attribute is a unique Accounting ID, to link multiple related sessions in a log file
Acct-Link-Count	51	O	Integer	Count of links in a multi-link session, when an accounting record is generated.
Event-Timestamp	55	O	Integer	This attribute is included in the accounting-request packet for recording the time in seconds that the event occurred on NAS. For example, January 1, 2013 00:00 UTC.
NAS-Port-Type	61	O	Integer	Indicates the physical port type of NAS, which authenticates the user.
Connect-Info	77	O	String	This attribute is sent from the NAS to indicate the nature of the user's connection.
Chargeable User ID	89	C	String	This attribute is MSISDN or any chargeable user identity returned by the AAA server. This attribute is unchanged when it is received in the RADIUS Access Accept message.
Framed-Interface-Id	96	O	Integer	The IPv6 interface identifier associated with a session, which is always sent with framed-IPv6 prefix. If present

TABLE 31 Accounting start message attributes (continued)

Attribute	Attribute ID	Presence	Type	Description
				<p>should match the session context.</p> <p>Note: This attribute is included in the Accounting message from AP only if the client is assigned with IPv6 address. If the address is IPv4, this attribute will not be part of the accounting message.</p>
Framed-IPv6-Prefix	97	O	Integer	<p>The IPv6 prefix associated with a session, which is always sent with framed interface identifier. If present should match the session context.</p> <p>Note: This attribute is included in the Accounting message from AP only if the client is assigned with IPv6 address. If the address is IPv4, this attribute will not be part of the accounting message.</p>
Location-Information	127	M	Octets	<p>This is a composite attribute, which provides meta data about the location information. It is encoded as per RFC 5580.</p> <p>NOTE This attribute is included only when the expected location delivery method is accounting request as specified in RFC 5580.</p>
Location-Data	128	C	Octets	<p>This attribute contains the actual location information. It is encoded as per RFC 5580.</p> <p>NOTE This attribute is included only when the expected location delivery method is accounting request as specified in RFC 5580.</p>

TABLE 31 Accounting start message attributes (continued)

Attribute	Attribute ID	Presence	Type	Description
Basic-Location-Policy-Rules	129	M	String	<p>This attribute provides the basic privacy policy associated to the location information. It is encoded as per RFC 5580.</p> <p>NOTE This attribute is included only when the expected location delivery method is accounting request as specified in RFC 5580.</p>
Extended-Location-Policy-Rules	130	C	Octets	<p>This attribute provides the extended privacy policy for the target whose location is specified. This attribute is sent with the above attribute (<i>basic location policy</i>). It is encoded as per RFC 5580.</p> <p>NOTE This attribute is included only when the expected location delivery method is accounting request as specified in RFC 5580.</p>

Accounting Interim Update and Stop Messages

The table lists the attribute details of messages sent by the controller to AAA.

TABLE 32 Accounting interim update and stop message attributes

Attribute	Attribute ID	Presence	Type	Description
User-Name	1	M	String	The username of the given accounting session.
NAS-IP-Address	4	C	Integer	This attribute is the IP address of the AP which is serving the station or controller's control IP address, controller's management IP address and user defined value.
NAS-Port	5	O	Integer	This attribute indicates the physical port number of the NAS which authenticates the user. The controller uses the association ID

TABLE 32 Accounting interim update and stop message attributes (continued)

Attribute	Attribute ID	Presence	Type	Description
				for the STA in the AP to represent this.
Framed-IP-Address	8	O	IP Address	This attribute indicates the address to be configured for the user.
Vendor-Specific	26	C	Integer	Vendor ID: Ruckus:25053 VSA: Ruckus-STA-RSSI (2) VSA Length: 6 UE reports the current RSSI value in the accounting packet. Ruckus VSA is received only from Ruckus AP.
Vendor-Specific	26	C	String	Vendor ID: Ruckus:25053 VSA: Ruckus-SSID (3) VSA Length: Variable Reports the associated WLANs SSID in the access request and accounting packet. Ruckus VSA is received only from Ruckus AP. It is optional for 3rd party APs.
Vendor-Specific	26	C	String	Vendor ID: Ruckus:25053 VSA: Ruckus-Location (5) VSA Length: Variable Reports the device location for this AP. This is a configurable value in the device location setting. Ruckus VSA is received only from Ruckus AP. It is optional for 3rd party APs.
Vendor-Specific	26	C	Integer	Vendor D: Ruckus:25053 VSA: Ruckus-SCG-CBLADE-IP (7) VSA Length: 6 Reports the control plane IP address. Ruckus VSA is received only from Ruckus AP. It is optional for 3rd party APs.
Vendor-Specific	26	C	Integer	Vendor ID: Ruckus:25053 VSA: Ruckus-SCG-DBLADE-IP (8) VSA Length: 6 Reports the data plane address. Ruckus VSA is received only from Ruckus AP. It is optional for 3rd party APs.
Called Station ID	30	O	String	This attribute allows NAS to send the ID (BSSID), which is called by the user. It is MAC of the AP. It supports 2 types of values, namely BSSID:SSID, where BSSID is the MAC address of the WLAN on AP.

Accounting - Controller Initiated Accounting Messages
AP Initiated Accounting Messages (PDG/LBO Sessions)

TABLE 32 Accounting interim update and stop message attributes (continued)

Attribute	Attribute ID	Presence	Type	Description
				The second value is AP-MAC:SSID, where AP-MAC is the MAC address of the AP. The letters in the MAC address are in uppercase. For example: 11-22-33-AA-BB-CC:SSID
Calling Station ID	31	O	String	Allows NAS to send the ID (UE MAC), which indicates as to who is calling this server.
NAS-Identifier	32	C	Integer	NAS-IP-Address or NAS-Identifier attribute is mandatory in received messages. It supports 3 types of values, namely BSSID (MAC address of the WLAN on AP), AP-MAC (MAC address of AP) and user defined address (maximum length of 62).
Proxy-State	33	O	Octets	This attribute is available to be sent by a proxy server (controller) to another server (AAA server) when forwarding an access request, accounting request (start, stop or interim) and <u>must</u> be returned unmodified in the access accept, access reject, access challenge and accounting response.
Acct-Status-Type	40	M	Integer	Value differs based on message type. Attribute <i>interim update</i> has the value 3 and <i>stop</i> has the value 2.
Acct-Delay-Time	41	C	Integer	This is a configurable option and by default this attribute is disabled. In case the accounting message gets retransmitted, this attribute contains the time stamp of the consecutive retransmitted message.
Acct-Input-Octets	42	M	Integer	This attribute indicates the number of octets received from the port over the course of the service provided. This attribute is present in <i>Acct-Status-Type = Interim, Stop</i> .
Acct-Output-Octets	43	M	Integer	This attribute indicates the number of octets sent to the port in the course of delivering this service.
Acct-Session-ID	44	M	Integer	This attribute is a unique accounting identity to facilitate easy matching of start, interim and stop records in a log file. The start, interim and stop records for a given session must have the same <i>Acct-Session-ID</i> .
Acct-Authentic	45	M	Integer	This attribute indicates whether the user was authenticated through

TABLE 32 Accounting interim update and stop message attributes (continued)

Attribute	Attribute ID	Presence	Type	Description
				RADIUS server or NAS or remote authentication protocol.
Acct-Session-Time	46	M	Integer	This attribute indicates the number of seconds for receiving the service.
Acct-Input-Packets	47	M	Integer	This attribute indicates the number of packets received from the port over the course of the service provided to a framed user.
Acct-Output-Packets	48	M	Integer	This attribute indicates the number of packets sent from the port over the course of the service provided to a framed user.
Acct-Terminate-Cause	49	M	Integer	This attribute indicates how the session was terminated. This attribute can only be present in accounting request records where the Acct-Status-Type is set to Stop.
Acct-Multi-Session-ID	50	O	Integer	This attribute is a unique Accounting ID, linking multiple related sessions in a log file.
Acct-Link-Count	51	O	Integer	Count of links in a multi-link session, when an accounting record is generated.
Acct-Input-Gigawords	52	M	Integer	This attribute indicates the number of times that the <i>Acct-Input-Octets</i> counter wraps around 2^{32} over the course of this provided service.
Acct-Output-Gigawords	53	M	Integer	This attribute indicates the number of times the <i>Acct-Output-Octets</i> counter is wrapped around 2^{32} in the course of delivering this service.
Event-Timestamp	55	O	Integer	This attribute is included in the accounting request packet to record the time (in seconds) that this event occurred on NAS. For example, January 1, 2013 00:00 UTC.
NAS-Port-Type	61	O	Integer	Indicates the physical port type of NAS, which authenticates the user.
Connect-Info	77	O	String	This attribute is sent from the NAS to indicate the nature of the user's connection.
Chargeable User ID	89	C	String	AP includes Chargeable User ID attribute along with the values received from the AAA server. This attribute is unchanged when it is received in the RADIUS Access Accept message.
Location-Information	127	M	Octets	This is a composite attribute, which provides meta data about

Accounting - Controller Initiated Accounting Messages
AP Initiated Accounting Messages (PDG/LBO Sessions)

TABLE 32 Accounting interim update and stop message attributes (continued)

Attribute	Attribute ID	Presence	Type	Description
				<p>the location information. It is encoded as per RFC 5580.</p> <p>NOTE This attribute is included only when the expected location delivery method is accounting request as specified in RFC 5580.</p>
Location-Data	128	C	Octets	<p>This attribute contains the actual location information. It is encoded as per RFC 5580.</p> <p>NOTE This attribute is included only when the expected location delivery method is accounting request as specified in RFC 5580.</p>
Basic-Location-Policy-Rules	129	M	String	<p>This attribute provides the basic privacy policy associated to the location information. It is encoded as per RFC 5580.</p> <p>NOTE This attribute is included only when the expected location delivery method is accounting request as specified in RFC 5580.</p>
Extended-Location-Policy-Rules	130	C	Octets	<p>This attribute provides the extended privacy policy for the target whose location is specified. This attribute is sent with the above attribute (<i>basic location policy</i>). It is encoded as per RFC 5580.</p> <p>NOTE This attribute is included only when the expected location delivery method is accounting request as specified in RFC 5580.</p>

Accounting On Messages

The table lists the attribute details of messages sent by the controller to the AAA server.

TABLE 33 Accounting on message attributes

Attribute	Attribute ID	Presence	Type	Description
User-Name	1	M	String	The username of the given accounting session.
NAS-IP-Address	4	C	Integer	This attribute is the IP address of the AP which is serving the station or controller's control IP address, controller's management IP address and user defined value.
Vendor-Specific	26	C	String	Vendor ID: Ruckus:25053 VSA: Ruckus-SSID (3) VSA Length: - Variable Reports the associated WLANs SSID in the access request and accounting packet, Ruckus VSA is received only from Ruckus AP. It is optional for 3rd party APs.
Vendor-Specific	26	C	String	Vendor ID: Ruckus:25053 VSA: Ruckus-Location (5) VSA Length: Variable Reports the device location for this AP. This is a configurable value in the device location setting. Ruckus VSA is received only from Ruckus AP. It is optional for 3rd party APs.
Vendor-Specific	26	C	Integer	Vendor ID: Ruckus:25053 VSA: Ruckus-SCG-CBLADE-IP (7) VSA Length: 6 Reports the control plane IP address. Ruckus VSA is received only from Ruckus AP. It is optional for 3rd party APs.
Vendor-Specific	26	C	Integer	Vendor ID: Ruckus:25053 VSA: Ruckus-SCG-DBLADE-IP (8) VSA Length: 6 Reports the data plane IP address. Ruckus VSA is received only from Ruckus AP. It is optional for 3rd party APs.
Called Station ID	30	O	String	This attribute allows NAS to send the ID (BSSID), which is called by the user. It is MAC of the AP. It supports 2 types of values, namely BSSID:SSID, where BSSID is the MAC address of the WLAN on AP. The second value is AP-MAC:SSID, where AP-MAC is the MAC address of the AP. The letters in the

Accounting - Controller Initiated Accounting Messages
AP Initiated Accounting Messages (PDG/LBO Sessions)

TABLE 33 Accounting on message attributes (continued)

Attribute	Attribute ID	Presence	Type	Description
				MAC address are in uppercase. For example: 11-22-33-AA-BB-CC:SSID
NAS-Identifier	32	C	Integer	NAS-IP-Address or NAS-Identifier attribute is mandatory in received messages. It supports 3 types of values, namely BSSID (MAC address of the WLAN on AP), AP-MAC (MAC address of AP) and user defined address (maximum length of 62).
Proxy-State	33	O	Octets	This attribute is available to be sent by a proxy server (controller) to another server (AAA server) when forwarding an access request, accounting request (start, stop or interim) and must be returned unmodified in the access accept, access reject, access challenge and accounting response.
Acct-Status-Type	40	M	Integer	This attribute indicates whether the <i>Accounting-Request</i> attribute marks it as <i>Accounting-On (7)</i> and <i>Accounting-Off(8)</i> .
Acct-Delay-Time	41	C	Integer	In case the accounting message gets retransmitted, this attribute contains the time stamp of the consecutive retransmitted message.
Acct-Authentic	45	M	Integer	This attribute indicates whether the user was authenticated through RADIUS server or NAS or Remote authentication protocol.

Accounting Off Messages

The table lists the attribute details of messages sent by the controller to the AAA server.

TABLE 34 Accounting off message attributes

Attribute	Attribute ID	Presence	Type	Description
User-Name	1	M	String	The username of the given accounting session.
NAS-IP-Address	4	C	Integer	This attribute is the IP address of the AP which is serving the station or controller's control IP address, controller's management IP address and user defined value.
Vendor-Specific	26	C	String	Vendor ID: Ruckus:25053 VSA: Ruckus-SSID (3) VSA Length: Variable Reports the associated WLANs SSID in access request and accounting packet. Ruckus VSAs are

TABLE 34 Accounting off message attributes (continued)

Attribute	Attribute ID	Presence	Type	Description
				received from Ruckus APs only. It is optional for 3rd party APs.
Vendor-Specific	26	C	String	Vendor ID: Ruckus:25053 VSA: Ruckus-Location (5) VSA Length: Variable Reports the device location for this AP. This is a configurable value in the device location setting. Ruckus VSA is received only from Ruckus AP. It is optional for 3rd party APs.
Vendor-Specific	26	C	Integer	Vendor ID: Ruckus:25053 VSA: Ruckus-SCG-CBLADE-IP (7) VSA Length: 6 Reports the control plane IP address. Ruckus VSAs are received from Ruckus APs only. It is optional for 3rd party APs.
Vendor-Specific	26	C	Integer	Vendor ID: Ruckus:25053 VSA: Ruckus-SCG-DBLADE-IP (8) VSA Length: 6 Reports the data plane IP address. Ruckus VSA is received only from Ruckus AP. It is optional for 3rd party APs.
Called Station ID	30	O	String	This attribute allows NAS to send the ID (BSSID), which is called by the user. It is MAC of the AP. It supports 2 types of values, namely BSSID:SSID, where BSSID is the MAC address of the WLAN on AP. The second value is AP-MAC:SSID, where AP-MAC is the MAC address of the AP. The letters in the MAC address are in uppercase. For example: 11-22-33-AA-BB-CC:SSID.
NAS-Identifier	32	C	Integer	NAS-IP-Address or NAS-Identifier attribute is mandatory in received messages. It supports 3 types of values, namely BSSID (MAC address of the

Accounting - Controller Initiated Accounting Messages
AP Initiated Accounting Messages (PDG/LBO Sessions)

TABLE 34 Accounting off message attributes (continued)

Attribute	Attribute ID	Presence	Type	Description
				WLAN on AP), AP-MAC (MAC address of AP) and user defined address (maximum length of 62).
Proxy-State	33	O	Octets	This attribute is available to be sent by a proxy server (controller) to another server (AAA server) when forwarding an access request, accounting request (start, stop or interim) and <u>must</u> be returned unmodified in the <i>Access Accept</i> , <i>Access Reject</i> , <i>Access Challenge</i> and <i>Accounting Response</i> .
Acct-Status-Type	40	M	Integer	This attribute indicates whether the <i>Accounting-Request</i> attribute marks it as <i>Accounting-On (7)</i> and <i>Accounting-Off(0)</i> .
Acct-Delay-Time	41	C	Integer	In case the accounting message gets retransmitted, this attribute contains the time stamp of the consecutive retransmitted message.
Acct-Authentic	45	M	Integer	This attribute indicates whether the user was authenticated through RADIUS server or NAS or Remote authentication protocol.

AAA Server Dynamic Authorization and List of Vendor Specific Attributes

- Dynamic Authorization and List of Vendor Specific Attributes - AAA Server..... 109
- Service Authorization 109
- WISPr Vendor Specific Attributes..... 116
- Ruckus Wireless Vendor Specific Attributes..... 116

Dynamic Authorization and List of Vendor Specific Attributes - AAA Server

The AAA server initiates messages to the controller signaling an authorization change, as described in *RFC 5176, Dynamic Authorization Extensions to RADIUS*. This occurs when modifications are made to the subscriber GPRS profile at the HLR (via OAM). Reference *TS 29.234* describes these procedures on the Wm reference point using the diameter protocol.

The following sections list the message flow attributes utilized for RADIUS Dynamic Authorization Extension. Change of Authorization (CoA) and Disconnect Message (DM) messages can have any of the following attributes as a session identifier.

- User name
- CUI with MSISDN
- Acct-Sess-Id (Session identification attribute)

NOTE

Refer to the appendix [Use Case Scenarios](#) on page 125 for flow details on NAS IP, accounting session identifier and filter identifier.

Service Authorization

A change in service authorization is initiated at the AAA server.

For example, when the AAA server receives a MAP-InsertSubscriberData from the HLR along with the modified GPRS profile information (QoS) or is modified for any other reason the controller AAA proxy intercepts the CoA request. It checks if the CoA message contains a session identification attribute (such as user name) as well as attributes indicating the authorization changes (new QoS). Depending on these attributes the call flows could vary.

If the CoA request contains a session identification and the attribute - service-type(6) is set to authorize-only the controller responds with CoA NAK since the controller does not support CoA with service-type as authorize-only.

If the CoA request does not contain the service-type(6) attribute, the message must contain a session identification attributes as well as authorization attributes (QoS).

The controller supports RADIUS CoA (Change-of-Authorization) in limited form. RADIUS CoA is supported only for modifying QoS profile when subscriber traffic is tunneled to the core network (Gn and S2a) interface. It is also supported when traffic originates from Ruckus Wireless or from third Party APs.

This section covers:

- [Change of Authorization \(CoA\) Messages - Not Set to Authorize Only](#) on page 110
- [Change of Authorization Acknowledge Message \(CoA Ack\)](#) on page 112
- [Change of Authorization Negative Acknowledge Messages \(CoA NAK\)](#) on page 112
- [Disconnect Messages](#) on page 113
- [Acknowledgment of Disconnect Messages \(DM Ack\)](#) on page 115
- [Negative Acknowledge of Disconnect Messages \(DM NAK\)](#) on page 115
- [Disconnect Messages - Dynamic Authorization Client \(AAA server\)](#) on page 115

NOTE

Refer to the Authentication and Authorization section for this procedure.

Change of Authorization (CoA) Messages - Not Set to Authorize Only

The table lists the attribute details of CoA messages where the Authorize-Only is not set. CoA can have any of the following attributes as session identifier:

- User name
- CUI with MSISDN
- Acct-Sess-Id
- NAS-Port
- Framed-IP-Address
- Called-Station-Id
- Acct-Multi-Session-Id
- Framed-Interface-Id
- Framed-IPv6-Prefix
- NAS-IPv6-Address

TABLE 35 Change of Authorization (CoA) messages - Authorize-Only is not set

Attribute	Attribute ID	Presence	Type/Description
Message Code		M	43
User-Name	1	C	Identifies the username of the UE/subscriber to be disconnected. Username is received from NAS during authentication or accounting session.
NAS-IP-Address	4	C	This attribute is the IP address of the AP which is serving the station or controller's control IP address, controller's management IP address and user defined value.
NAS-Port	5	O	Indicates the physical NAS port number, which authenticates the user or the port on which a session is terminated. If present should match the session context table.
Service-Type	6	O	This attribute indicates the type of service the user has requested, or the type of service to be provided. CoA request should be processed if present.

TABLE 35 Change of Authorization (CoA) messages - Authorize-Only is not set (continued)

Attribute	Attribute ID	Presence	Type/Description
			<p>NOTE Changes do not get applied on the UE session. It ignores the parameter.</p>
Framed-IP-Address	8	O	The IPv4 address associated with a session. This is the IP address, which gets assigned to UE after successful call establishment. If present should match the session context table.
Filter-Id	11	O	Represents the user role name sent by AAA. This is used by the controller to map the received Group Role Name to the UTP profile and forward the corresponding ACL/rate limiting parameters to NAS. NAS enforces the UTP for the given user.
3GPP VSA (Negotiated-QoS-Profile)	5	O	<p>This attribute carries the new QoS value and can be either be Ruckus defined VSA or 3GPP defined VSA.</p> <p>NOTE The controller uses this attribute for updating the QoS from the AAA server, whichever is present. If both are present priority is for 3GPP-QoS attribute.</p>
Vendor-Specific	26	O	<p>Vendor ID: WISPr: 14122</p> <p>VSA: WISPr-Bandwidth-Max-UP (7)</p> <p>VSA Length: Variable</p> <p>The attribute contains the maximum uplink value in bits per second.</p>
Vendor-Specific	26	O	<p>Vendor ID: WISPr: 14122</p> <p>VSA: WISPr-Bandwidth-Max-DOWN (8)</p> <p>VSA Length: Variable</p> <p>The attribute contains the maximum downlink value in bits per second.</p>
Session-Timeout	27	O	This attribute sets the maximum number of seconds of service to be provided to the user before termination of the session
Idle-Timeout	28	O	It sets the maximum number of consecutive seconds of idle connection allowed to the user before termination of the session.
Called Station ID	30	O	String. This attribute will contain the Called Station ID as received from NAS during authentication or the accounting procedure.
Calling Station ID	31	O	String. This attribute will contain the Calling Station ID as received from NAS during authentication or the accounting procedure
NAS-Identifier	32	C	If present, it should match with the value in the controller session table.
Acct-Session-ID	44	C	This attribute should have the same value as sent by NAS during the accounting procedure.

TABLE 35 Change of Authorization (CoA) messages - Authorize-Only is not set (continued)

Attribute	Attribute ID	Presence	Type/Description
State	45	O	This attribute is copied as is if it is received in a request from the AAA server. NOTE Changes do not get applied on the UE session. It ignores the parameter.
Acct-Multi-Session-Id	50	O	This attribute uniquely identifies related sessions. It should have the same value received in authentication or accounting request. If present should match the session context table.
Accounting-Interim-Interval	85	O	Indicates the number of seconds between each interim update for this specific session. If the value is blank, the configured default value is used as the accounting interim interval.
Chargeable User ID	89	C	String. This attribute is MSISDN or any chargeable user identity returned by the AAA server.
NAS-IPv6-Address	95	O	This attribute is the IPv6 address of the AP which is serving the station or controller's control IP address, controller's management IP address and user defined value
Framed-Interface-Id	96	O	The IPv6 interface identifier associated with a session, which is always sent with framed-IPv6 prefix. If present should match the session context.
Framed-IPv6-Prefix	97	O	The IPv6 prefix associated with a session, which is always sent with framed interface identifier. If present should match the session context.

Change of Authorization Acknowledge Message (CoA Ack)

The table lists the attributes of CoA messages being acknowledged by the controller to DAC.

TABLE 36 Change of Authorization (CoA) messages - Acknowledge

Attribute	Attribute ID	Presence	Type/Description
Message Code		M	44
State	24	C	This attribute is copied without any modification or only if it is sent in the CoA request.

Change of Authorization Negative Acknowledge Messages (CoA NAK)

The table lists the attributes of CoA messages that are not acknowledged by the controller to the DAC.

TABLE 37 Change of Authorization (CoA) messages - Negative Acknowledge

Attribute	Attribute ID	Presence	Type/Description
Message Code		M	45
Service-Type	6	C	Indicates the type of service based on the user request or the type of service to be provided. It is included only if the Service-Type attribute is present in CoA request, is set to <i>authorize only</i> .

TABLE 37 Change of Authorization (CoA) messages - Negative Acknowledge (continued)

Attribute	Attribute ID	Presence	Type/Description
State	24	C	This attribute is copied without any modification or only if it is sent in the CoA request.
Error-Cause	101	C	Included only if the Service-Type attribute present in the CoA request is set to <i>authorize only</i> . It is included only if the Error-Cause attribute is set to <i>request initiated</i> . NOTE For other scenarios, the attribute Error-Cause will have the value as mentioned in TS.

Disconnect Messages

The table lists the attributes of disconnect messages, which are initiated by the controller.

TABLE 38 Disconnected messages

Attribute	Attribute ID	Presence	Type/Description
Message Code		M	40
User-Name	1	M	Identifies the user name of the UE/ subscriber to be disconnect. User name received from NAS during authentication or accounting session.
NAS-IP-Address	4	C	If present, it should match with the value in the controller session table.
NAS-Port	5	O	Indicates the physical NAS port number, which authenticates the user or the port on which a session is terminated. If present should match the session context table.
Service-Type	6	O	This attribute indicates the type of service the user has requested, or the type of service to be provided. DM request should be processed if present. NOTE Changes do not get applied on the UE session. It ignores the parameter.
Framed-IP-Address	8	O	The IPv4 address associated with a session. This is the IP address, which gets assigned to UE after successful call establishment. If present should match the session context table.
Acct-Terminate-Cause	24	O	This attribute has a value 6 for admin reset.
Calling Station ID	31	C	This attribute will contain the Calling Station ID as received from NAS

TABLE 38 Disconnected messages (continued)

Attribute	Attribute ID	Presence	Type/Description
			during authentication or the accounting procedure.
NAS-Identifier	32	C	It supports 3 types of values, namely BSSID (MAC address of the WLAN on AP), APMAC (MAC address of AP) and user defined address (maximum length of 62).
Acct-Session-ID	44	C	This attribute should have the same value as sent by NAS during accounting procedure.
State	45	O	This attribute is copied as is if it is received in a request from the AAA server.
Acct-Terminate-Cause	49	M	This attribute indicates how the session was terminated. Value 6 is for admin reset.
Acct-Multi-Session-Id	50	O	This attribute uniquely identifies related sessions. It should have the same value received in authentication or accounting request. If present should match the session context table.
Message Authenticator	80	O	This attribute is used to sign <i>access requests</i> to prevent spoofing access requests using CHAP, ARAP or EAP authentication methods. It authenticates this whole RADIUS packet - HMAC-MD5 (Type Identifier Length Request Authenticator Attributes).
NAS-Port-Id	87	O	String identifying the port based on the session and should match the session context if present in request.
Chargeable User ID	89	C	This attribute is MSISDN or any chargeable user identity returned by the AAA server.
NAS-IPv6-Address	95	O	This attribute is the IPv6 address of the AP which is serving the station or controller's control IP address, controller's management IP address and user defined value
Framed-Interface-Id	96	O	The IPv6 interface identifier associated with a session, which is always sent with framed-IPv6 prefix. If present should match the session context.
Framed-IPv6-Prefix	97	O	The IPv6 prefix associated with a session, which is always sent with framed interface identifier. If present should match the session context.

Acknowledgment of Disconnect Messages (DM Ack)

The table lists the attributes of disconnect messages, which are acknowledged.

TABLE 39 Acknowledgment of disconnect messages

Attribute	Attribute ID	Presence	Type/Description
Message Code		M	41
Acct-Terminate-Cause	49	O	This attribute indicates how the session was terminated. Value for <i>Admin-Reset</i> is set to 6

Negative Acknowledge of Disconnect Messages (DM NAK)

The table lists the attributes of disconnect messages, which are not acknowledged.

TABLE 40 Negative acknowledgment of disconnect messages

Attribute	Attribute ID	Presence	Type/Description
Message Code		M	42
Error-Cause	101	C	Included only if the <i>Service-Type</i> attribute is present in CoA request is set to <i>authorize only</i> . It is included only if the <i>Error-Cause</i> attribute is set to <i>request initiated</i> .

Disconnect Messages - Dynamic Authorization Client (AAA server)

A disconnect request packet is sent by the Dynamic Authorization Client for terminating user session(s) on a NAS and to discard all associated session context. The disconnect request packet is sent to UDP port 3799 where it identifies the NAS and user session(s) to be terminated by including the identification attributes.

Disconnect messages can have any of the following attributes as a session identifier.

- User name
- CUI with MSISDN
- Acct-Sess-Id

The table lists the attribute details of the disconnect messages, which are initiated by the dynamic authorization client of the AAA server.

TABLE 41 Disconnected messages initiated by dynamic authorization client (DAC)

Attribute	Attribute ID	Presence	Type/Description
Message Code		M	40
User-Name	1	C	Identifies the username of the UE/subscriber to disconnect. Username received from NAS during authentication or accounting session.
NAS-IP-Address	4	C	This attribute is the IP address of the AP which is serving the station or controller's control IP address, controller's management IP address and user defined value.
Calling Station ID	31	O	String. This attribute will contain the Calling Station ID as received from NAS during authentication or the accounting procedure.
NAS-Identifier	32	C	If present, it should match with the value in the controller session table.
Proxy-State	33	O	Octets. This attribute is available to be sent by a proxy server to another server.

TABLE 41 Disconnected messages initiated by dynamic authorization client (DAC) (continued)

Attribute	Attribute ID	Presence	Type/Description
Acct-Session-ID	44	C	This attribute should have the same value as sent by NAS during accounting procedure.
Chargeable User ID	89	C	String. This attribute is MSISDN or any chargeable user identity returned by the AAA server.

WISPr Vendor Specific Attributes

The table lists the WISPr vendor specific attributes. The VSA ID for the following VSAs is 14122 and the type is 26.

TABLE 42 WISPr vendor specific attributes - 14122

Attribute Name	Attribute ID	RADIUS Message Type	Purpose
WISPr-Location-ID	1	Access-Accept Accounting Start - Stop	This attribute indicates the WISPr location id for the specified WISPr service.
WISPr-Location-Name	2	Access-Accept Accounting Start - Stop and Interim	This attribute indicates the WISPr location name for the specified WISPr service.
WISPr-Bandwidth-Max-UP	7	Access-Accept	This attribute specifies the maximum rate at which the corresponding user is allowed to transmit for upstream data.
WISPr-Bandwidth-Max-DOWN	8	Access-Accept	This attribute specifies the maximum rate at which the corresponding user is allowed to transmit for downstream data.

Ruckus Wireless Vendor Specific Attributes

All Ruckus Wireless vendor specific attributes are encoded as sequence of:

- Vendor type
- Vendor length
- Value fields

The figure shows the VSA fields.

FIGURE 8 VSA fields

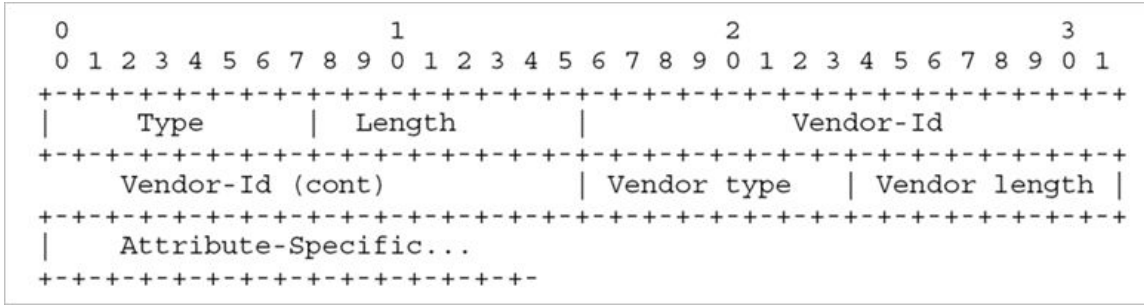

The table lists the Ruckus Wireless vendor specific attributes. The VSA ID for all the following VSAs is 25053 and type is 26.

TABLE 43 Ruckus Wireless vendor specific attributes - 25053

Attribute Name	Attribute ID	RADIUS Message Type	Purpose
Ruckus-User-Groups	1	Access-Accept	RADIUS server uses this attribute to indicate the access point group, specifying the UE group.
Ruckus-STA-RSSI	2	Accounting - Interim - Stop	This attribute reports the UEs current RSSI value in the accounting packet.
Ruckus-SSID	3	Access- Request Accounting - Start -Interim- Stop	This attribute reports the associated WLANs SSID in the access request and accounting packet.
Ruckus-WLan-ID	4	Access- Request Accounting - Start -Interim- Stop	This attribute reports the associated WLANs ID. Ruckus VSA is received only from Ruckus AP. Note: It is optional for 3rd party APs.
Ruckus-Location	5	Access- Request Accounting - Start -Interim- Stop	This attribute reports the device location for the current/ specified access point. This is a configurable value in the device location setting. Ruckus VSA is received only from Ruckus AP. It is optional for 3rd party APs.
Ruckus-Grace-Period	6	Access- Request Accounting - Start -Interim- Stop	This attribute is the grace period in hotspot WLANs.
Ruckus-SCG-CBLADE-IP	7	Access- Request Accounting - Start -Interim- Stop	This attribute reports the control plane IP address.
Ruckus-SCG-DBLADE-IP	8	Access- Request Accounting - Start -Interim- Stop	This attribute reports the data plane IP address.
Ruckus-VLAN-ID	9	Access-Accept	This attribute value is as per the configuration specified on the WLAN configuration page of the controller web interface. Refer to Figure 8 .

AAA Server Dynamic Authorization and List of Vendor Specific Attributes
Ruckus Wireless Vendor Specific Attributes

TABLE 43 Ruckus Wireless vendor specific attributes - 25053 (continued)

Attribute Name	Attribute ID	RADIUS Message Type	Purpose
Ruckus-Sta-Expiration	10		This attribute indicates the expiration value from the RADIUS server.
Ruckus-Sta-UUID	11		This attribute indicates the UUID value from the RADIUS server, when the UUID exists.
Ruckus-Accept-Enhancement-Reason	12		This attribute indicates the reason from the RADIUS server, when the reason exists.
Ruckus-Sta-Inner-Id	13		This attribute indicates the user name from the RADIUS server, when the user exists.
Ruckus-BSSID	14		BSSID for each WLAN in each radio
Ruckus-IMSI	102	Accounting - Start-Stop	This is sent by AAA to the controller as an authorization accept RADIUS message. M-controller utilizes this information to create the PDP context toward GGSN. Refer to Figure 8 .
Ruckus-MSISDN	103		The CUI is generally used, but MSISDN can also be used. ♦
Ruckus-APN	104	Access- Request Accounting - Start - Stop	This attribute carries the APN subscribed by the user. It contains only the network identifier (NI), which is part of the APN. The operator identifier part is stored separately in Ruckus-APN-OI. Note: This attribute is always sent and received as a string format, as explained in Figure 8 .
Ruckus-QoS	105		3GPP-QoS is now used instead of this VSA. However, this VSA is supported in 2.1.x releases.
Ruckus-NAS-Type	109	Accounting - Start	The value for this parameter is always 1. Refer to the encoding as explained in Figure 8 .
Ruckus-Status	110		The Accounting Response does not have a status type. This attribute was added to inform AUT that the Accounting has failed due to the setting of this VSA.
Ruckus-APN-OI	111	Access-Accept Accounting - Start	It contains the Operator ID, which is part of the APN name. APN NI part is sent in the Ruckus-APN attribute.

TABLE 43 Ruckus Wireless vendor specific attributes - 25053 (continued)

Attribute Name	Attribute ID	RADIUS Message Type	Purpose
			Refer to the encoding as explained in Figure 8 .
Ruckus-Session-Type	125	Access- Accept	The controller server uses this attribute on the access-accept to indicate forward policy of the specific UE.
Ruckus-Acct-Status	126	Access- Accept	The controller server uses this attribute on the Access Accept to indicate if the authenticator needs to send the accounting start for the current/specified client.
Ruckus-Zone-ID	127	Access- Request	The controller server uses this attribute to report the zone ID to which the 3rd party AP is associated. This VSA is received only for 3rd party APs.
Ruckus-Auth-Server-Id	128		RAS (IDM) and SCG-RACC use this attribute to obtain the AAA UUID from RAS (IDM) and SCG-RAC.
Ruckus-Utp-Id	129		SCG-RAC and Ruckus-AP use this attribute to provide the UTP ID value to the AP.
Ruckus-Area-Code	130		This attribute carries the area code of the NAS location.
Ruckus-Cell-Identifier	131		This attribute carries the cell ID of the NAS location.
Ruckus-Wispr-Redirect-Policy	132		External AAA and SCG-RAC use this attribute to get the vanilla values for the WISPr-TTG feature.
Ruckus-Eth-Profile-Id	133		Ruckus-AP and SCG-RAC use this attribute to find the Ethernet-Profile-Id for a particular session
Ruckus-Zone-Name	134		SCG-RAC and the external AAA use this attribute to notify the Zone that the AP belongs to.
Ruckus-Wlan-Name	135		SCG-RAC and the external AAA use this attribute to notify the name of the WLAN that the AP belongs to.
Ruckus-Read-Preference	137		The NBI/RAC and external AAA use this attribute to notify the primary/secondary database from where the data is to be read.
Ruckus-Client-Host-Name	138	String	Host name of the client device which accesses the network.
Ruckus-Client-Os-Type	139	String	Operating System of the client device.

AAA Server Dynamic Authorization and List of Vendor Specific Attributes
Ruckus Wireless Vendor Specific Attributes

TABLE 43 Ruckus Wireless vendor specific attributes - 25053 (continued)

Attribute Name	Attribute ID	RADIUS Message Type	Purpose
Ruckus-Client-Os-Class	140	String	Operating System category group classes that represent the OS related objects on the client device.
Ruckus-Vlan-Pool	141	String	List of VLAN identifiers supported for WLAN. This attribute can be found only in RADIUS Access-Accept. APs use the MAC hashing to find the proper VLAN ID from the VLAN pool dynamically and tag all the user equipment data traffic.

AP Roaming Scenarios

- [AP Roaming Scenarios Overview.....](#) 121

AP Roaming Scenarios Overview

The AP roaming scenarios are as follows.

NOTE

The session timeout values received from the AAA server are used for maintaining the PMK/OKC cache timer values at the controller and AP. If the timer value received is less than the default value of 12 hours, it will be used. Otherwise the default value will be used as the maximum value.

Roaming from AP1 to AP2 - PMK / OKC Disabled

In this scenario as seen in the figure, the UE (subscriber) roams from AP1 to AP2. Authentication and accounting messages are initiated from the AP and the PMK (Pairwise Master Key) / OKC (Opportunistic Key Caching) cache is disabled.

FIGURE 9 UE roaming from AP1 to AP2 - PMK / OKC disabled

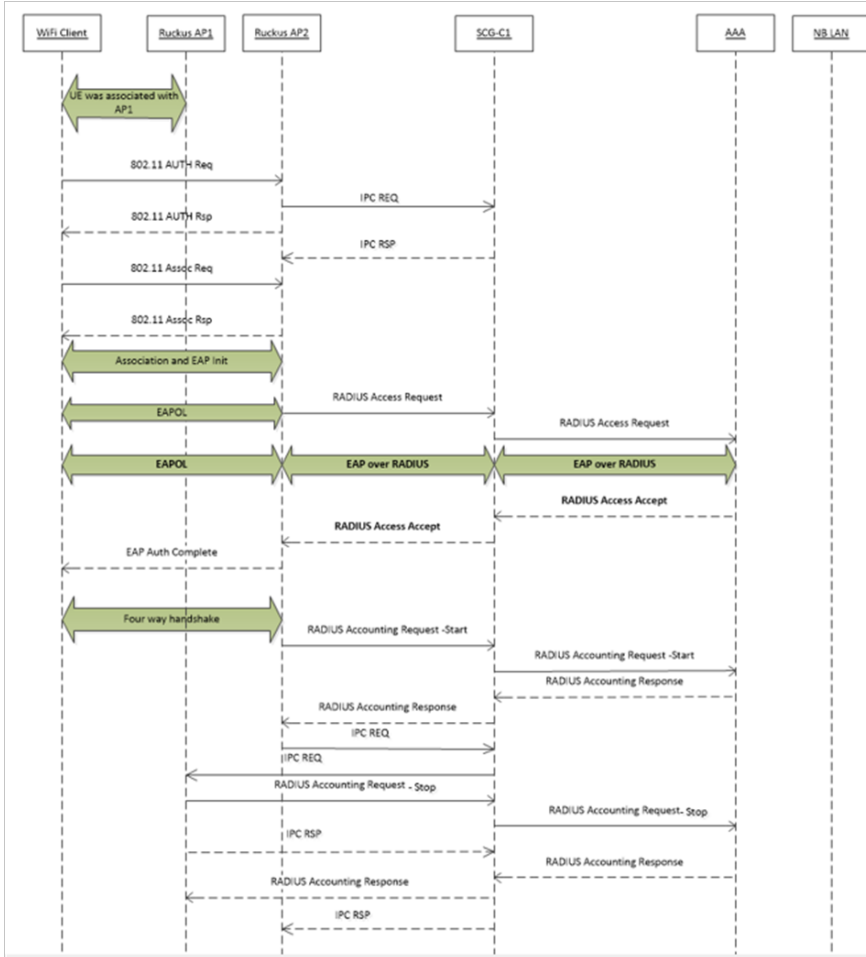

Roaming from AP1 to AP2 - PMK / OKC Enabled

In this scenario as seen in the figure, the UE (subscriber) roams from AP1 to AP2. Authentication and accounting messages are initiated from the AP and the PMK / OKC cache is enabled.

FIGURE 10 UE roaming from AP1 to AP2 - PMK / OKC enabled

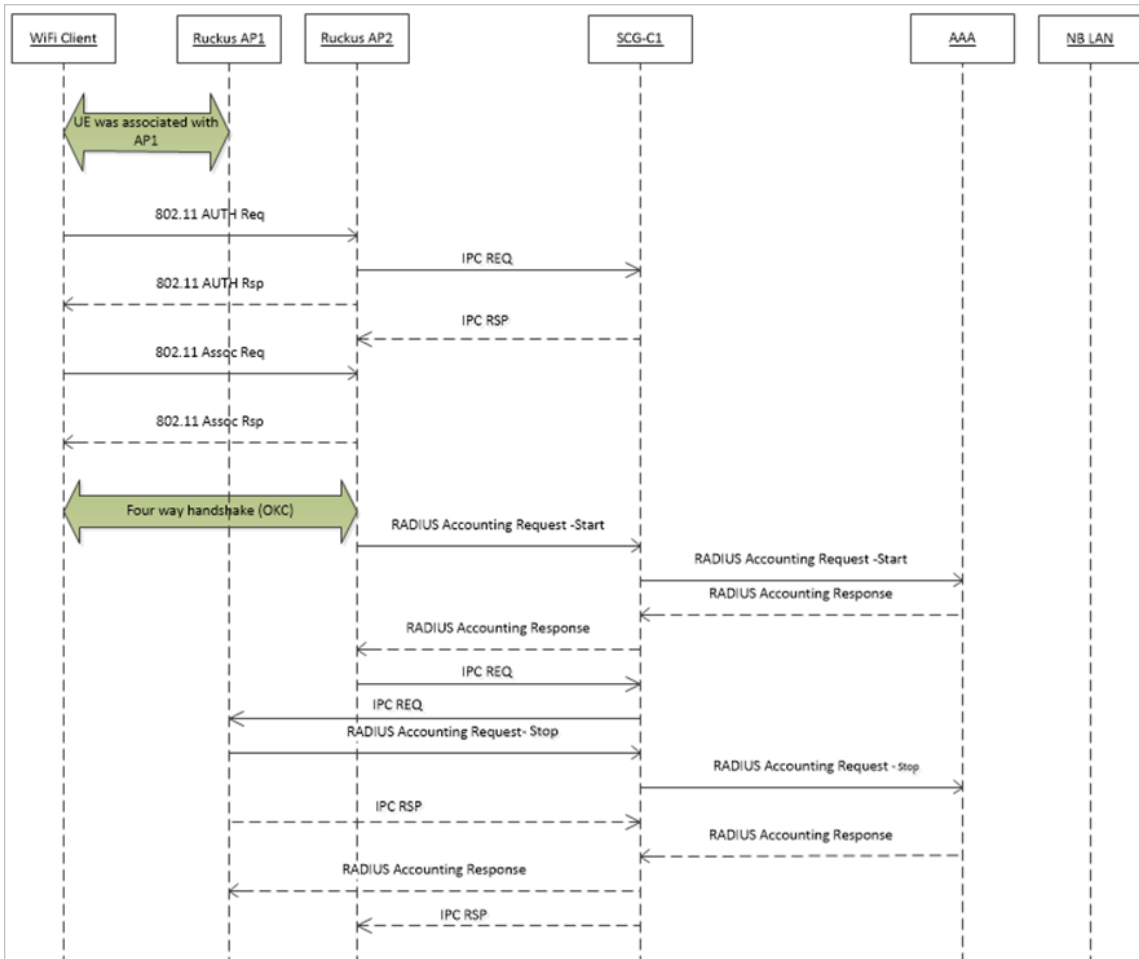

AP1 to AP2 Connected to Different Controller Node - PMK / OKC Disabled

In this scenario as seen in the figure, the UE (subscriber) roams from AP1 to AP2 with both the APs connected to the different controller nodes in a cluster environment. This scenario is specific to TTG sessions, where the controller has a GTP tunnel from the controller to the GGSN/PGW. The AP initiates authentication of messages whereas accounting messages are initiated by the controller. PMK / OKC cache is disabled.

FIGURE 11 UE roams from AP1 to AP2 connected to different controller node

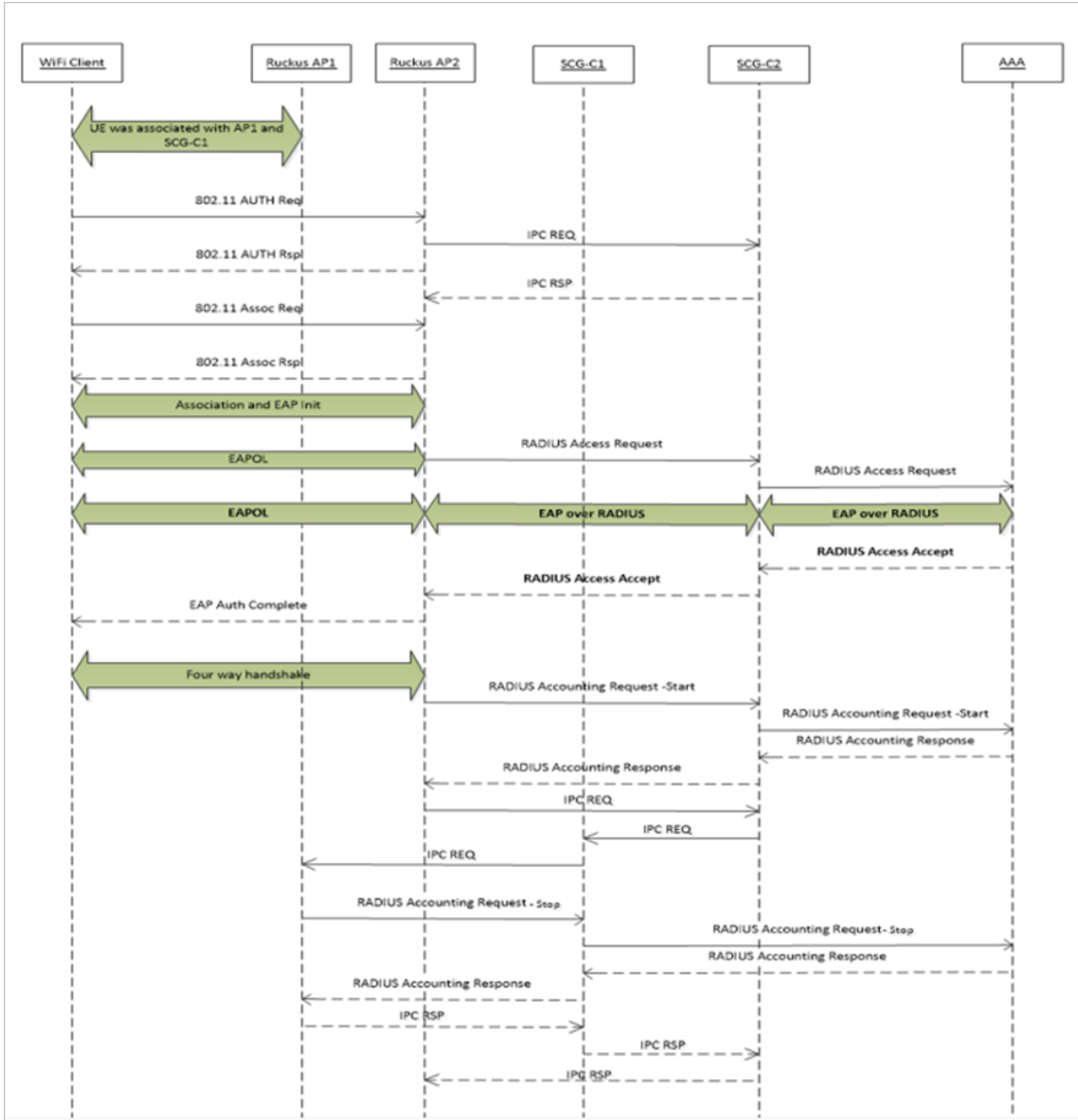

Use Cases

- Use Case Scenarios..... 125

Use Case Scenarios

The following are the use cases pertaining to NAS IP, Accounting session identifier and filter identifier.

Authentication and Accounting of NAS IP AVP

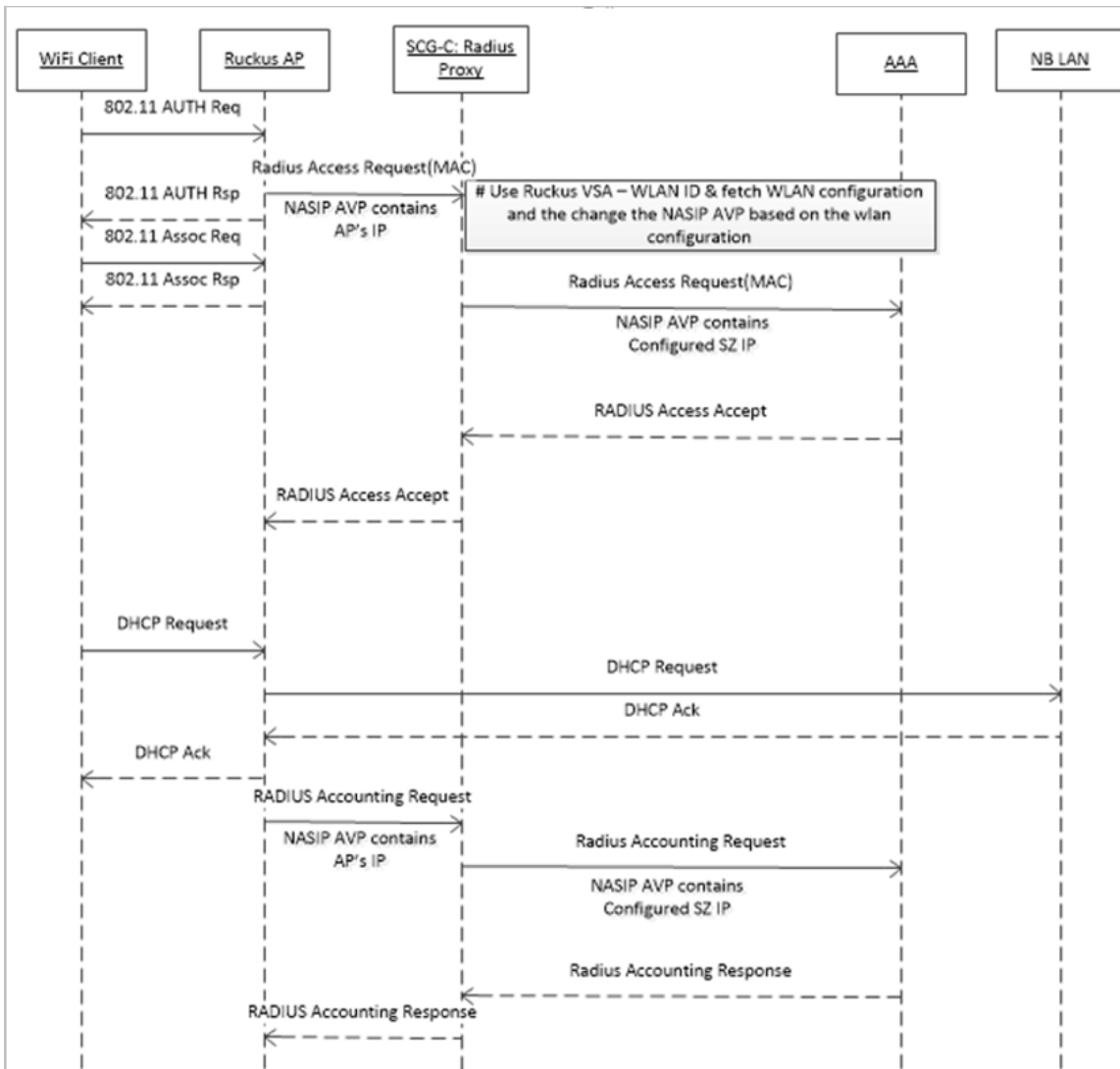

CoA / DM Handling with NAS IP AVP

Use Cases
Use Case Scenarios

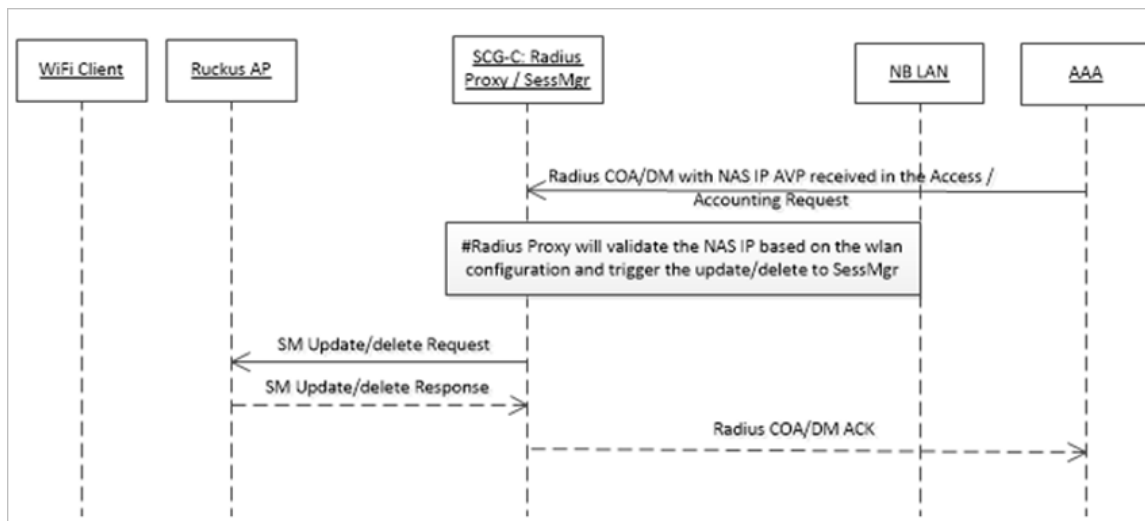

CoA Handling with Accounting Session Identifier

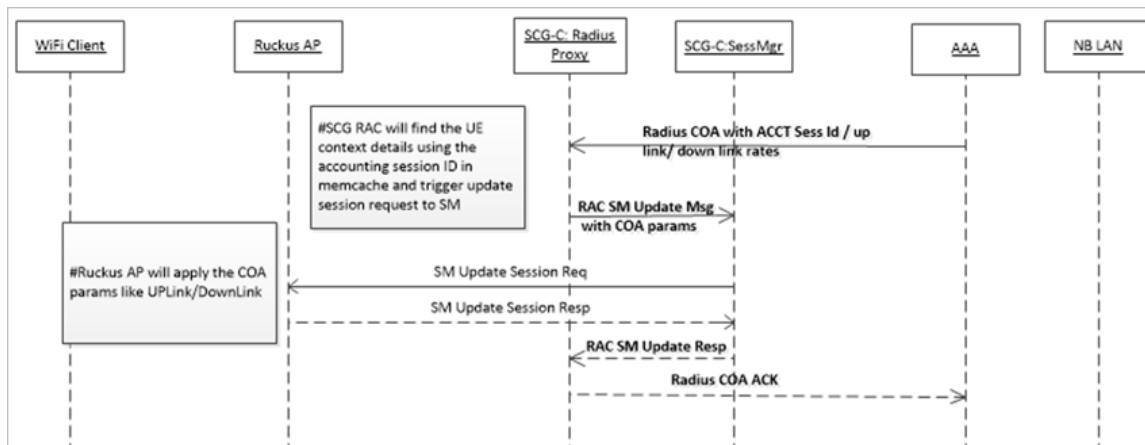

DM Handling with Accounting Session Identifier

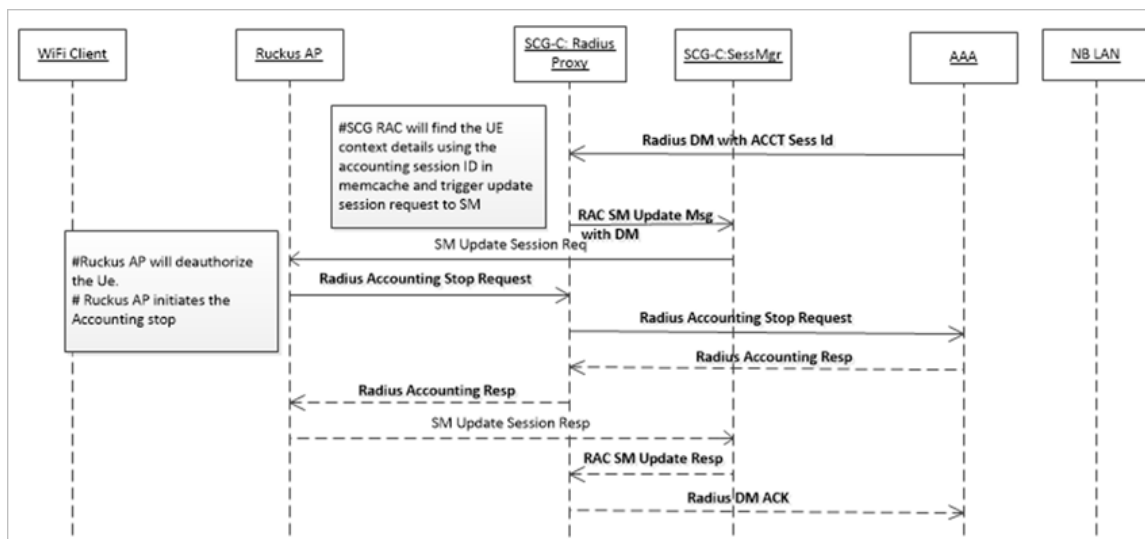

User Role change using Radius CoA - Filter Identifier

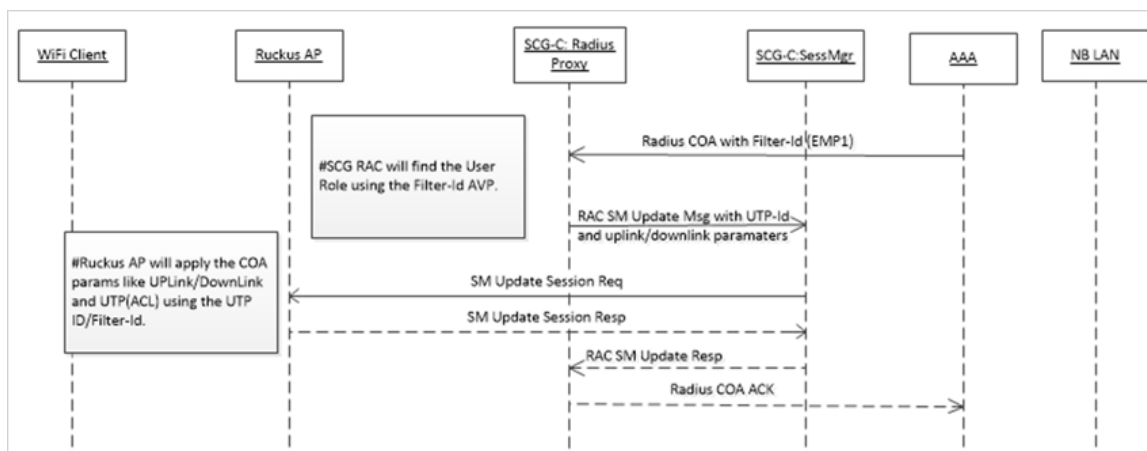

DPSK for Cloud over RADIUS

- [DPSK For Cloud Over Radius Overview.....](#)129

DPSK For Cloud Over Radius Overview

In the Wi-Fi world, there is always a need for securing access tunnel between the UE and the AP since the UE data traffic can be easily captured and the contents be seen by any networking monitoring devices.

There are two existing wireless encryption methods, Pre Shared Key(PSK) and 802.1X, for a secure channel over the air. Most common deployments are PSKs rather than 802.1X because of two main reasons:

1. Configuration on the UE is complex
2. Some devices do not support 802.1X

In PSK WLAN, each UE uses the same shared key (passphrase) to encrypt the data traffic. The main disadvantage of having PSK is that if one of the WLAN user is compromised to share the PSK then the entire user traffic can easily be cracked using the PSK.

This brought the need for having a secure tunnel for each user connected to the WLAN. Ruckus Wireless has come with the solution to provide a robust and secure wireless access for each individual user.

Ruckus supports Dynamic Pre Shared Key (DPSK) with the following modes.

- **Internal:** Ruckus controller or AP manages and retains the DPSK for each individual user with a very optimistic way of handling the DPSK. The number of DPSK supported is limited.
- **External:** Ruckus controller or AP supports the external mode, which uses the RADIUS interface with the Radius Server (AAA) for the DPSK to be maintained at one place. There is no limitation to the number of DPSKs supported. It also simplifies the usecases for the operators and service providers.

DPSK - External

Ruckus controller or AP uses the existing Mac-Authentication (Radius) functionalities to obtain the user DPSK and other session authorization parameters from Radius server (AAA) as seen in the figure below.

FIGURE 12 DPSK - External

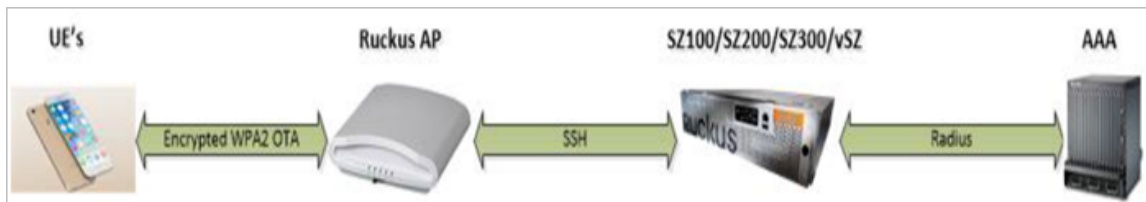

How does the DSPK Work

- AAA server generates and maintains the DPSK for each individual user through their UE MAC.
- During UE association, the controller or AP triggers the Radius Access Request to the Radius server (AAA)
- Radius server (AAA) sends back the Radius Access Accept with the new Ruckus VSA. If the user is found using the UE MAC, the Radius server can include other authorization parameter like session timeout/idle timeout/interim timeout/ user group(role) and more in the Radius Access Accept message.

DPSK for Cloud over RADIUS
DPSK For Cloud Over Radius Overview

- Radius server (AAA) sends back the Radius Access Reject if the UE MAC is not found in their data base. Ruckus AP or controller restricts the UE from being associated to the WLAN if it receives the access reject from the AAA server. Ruckus AP's are capable of barring the UE after couple of association attempts.

DPSK VSA

TABLE 44 DPSK VSA

VSA Attribute	Details
Attribute	Vendor-Specific
Attribute Type	26
Presence	Conditional
Vendor ID	Ruckus:25053
VSA	Ruckus-DPSK(142)
VSA Length	Variable

UE Association Call Flow

Radius AAA server includes the new Ruckus DPSK VSA to retain the PSK value. It also includes the *Filter-Id AVP* for the controller or AP to map the user role and apply the uplink or downlink rates, D-Vlan or Vlan-pool and ACL. The Radius AAA server also has all the other standard sessions related attributes. It also uses the session timeout to force the UE to re-associate (reauthenticate) with the AP and handles the expiry of the DPSK.

FIGURE 13 UE Association Call Flow

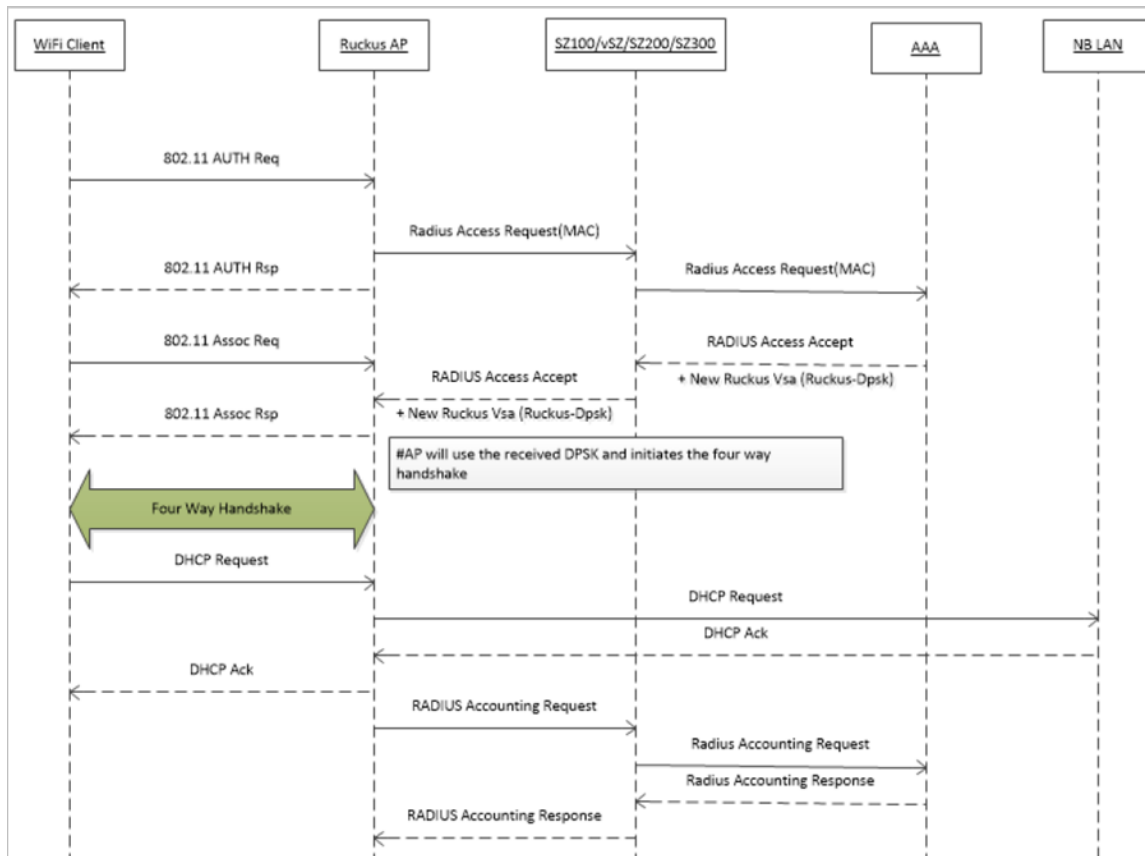

Radius Change of Authorization (CoA) Call Flow

Radius CoA is used for changing the authorization parameters like user role or all session related timeouts / uplink rate/downlink rate for the UE session. For example, if the user subscribes to a premium package when they are associated with the WLAN, then the Radius AAA server can trigger the CoA message to the controller and make the changes applied on the UE traffic.

FIGURE 14 CoA Call Flow

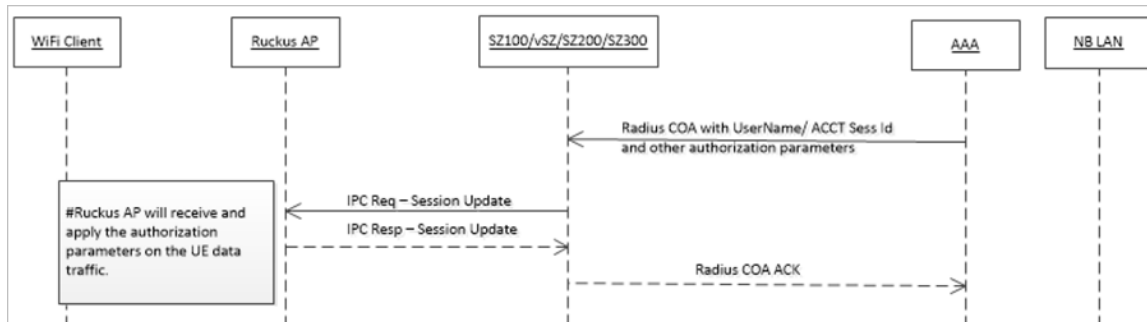

Radius Disconnect Message (DM) Call Flow

Radius DM is used for the de-authenticating the authorized UE from the AP and forces the UE to re-associate with the WLAN. For example, if the operator deletes the DPSK for the user or expiry of the DPSK or for other reasons.

FIGURE 15 DM Call Flow

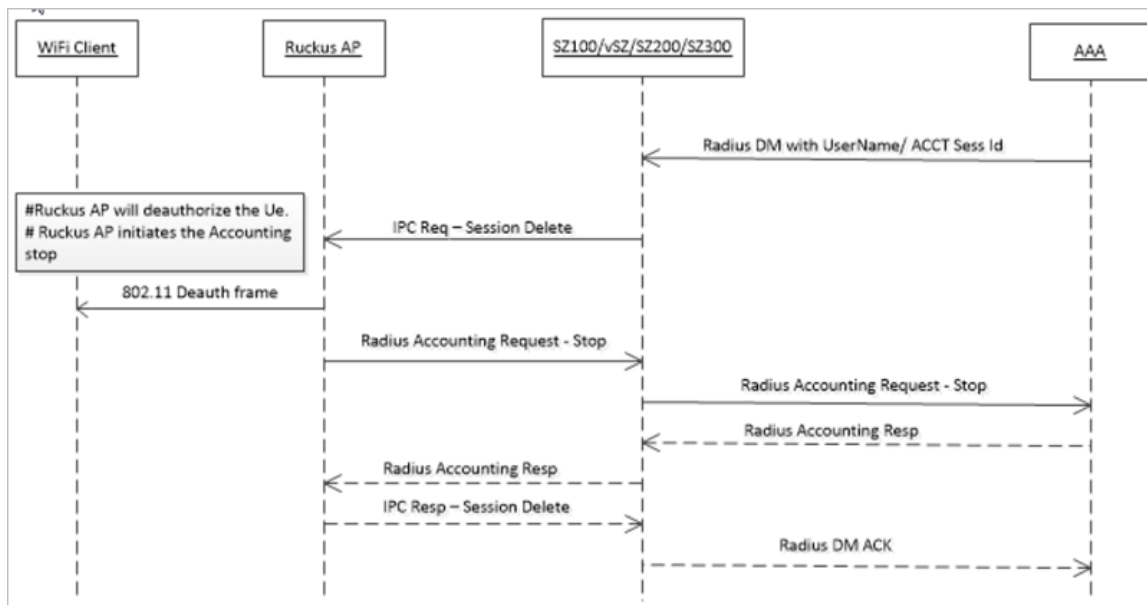



Copyright © 2006-2017. Ruckus Wireless, Inc.
350 West Java Dr. Sunnyvale, CA 94089. USA
www.ruckuswireless.com